

## 40Gbps QSFP IR4 TR-QQ13T-H00

### Features

- 4 CWDM lanes MUX/DEMUX design
- Up to 12.5Gbps data rate per wavelength
- QSFP MSA compliant
- IEEE 802.3ba Electrical Interface
- Up to 2 km transmission
- Optical link budget: 9.5dB
- Operating case temperature: 20~65C
- Maximum 3.5W operation power
- SMF LC duplex connector
- RoHS compliant



### Applications

- Data Center Interconnect
- 40G Ethernet
- Infiniband QDR
- 40G Campus Link

## 1. General Description

This product is a transceiver module designed for 2Km optical communication applications. The design is compliant to 40GBASE-LR4 of the IEEE P802.3ba standard. The module converts 4 inputs channels (ch) of 10Gb/s electrical data to 4 CWDM optical signals, and multiplexes them into a single channel for 40Gb/s optical transmission. Reversely, on the receiver side, the module optically de-multiplexes a 40Gb/s input into 4 CWDM channels signals, and converts them to 4 channel output electrical data.

The central wavelengths of the 4 CWDM channels are 1271, 1291, 1311 and 1331 nm as members of the CWDM wavelength grid defined in ITU-T G694.2. It contains a duplex LC connector for the optical interface and a 38-pin connector for the electrical interface. To minimize the optical dispersion in the long-haul system, single-mode fiber (SMF) has to be applied in this module.

The product is designed with form factor, optical/electrical connection and digital diagnostic interface according to the QSFP Multi-Source Agreement (MSA). It has been designed to meet the harshest external operating conditions including temperature, humidity and EMI interference.

## 2. Functional Description

This product converts the 4-channel 10Gb/s electrical input data into CWDM optical signals (light), by a driven 4-wavelength Distributed Feedback Laser (DFB) array. The light is combined by the MUX parts as a 40Gb/s data, propagating out of the transmitter module from the SMF. The receiver module accepts the 40Gb/s CWDM optical signals input, and de-multiplexes it into 4 individual 10Gb/s channels with different wavelength. Each wavelength light is collected by a discrete photo diode, and then outputted as electric data after amplified by a TIA. Figure 1 shows the functional block diagram of this product.

A single +3.3V power supply is required to power up this product. Both power supply pins VccTx and VccRx are internally connected and should be applied concurrently. As per MSA specifications the module offers 7 low speed hardware control pins (including the 2-wire serial interface): ModSelL, SCL, SDA, ResetL, LPMode, ModPrsL and IntL.

Module Select (ModSelL) is an input pin. When held low by the host, this product responds to 2-wire serial communication commands. The ModSelL allows the use of this product on a single 2-wire interface bus – individual ModSelL lines must be used.

Serial Clock (SCL) and Serial Data (SDA) are required for the 2-wire serial bus

communication interface and enable the host to access the QSFP memory map.

The ResetL pin enables a complete reset, returning the settings to their default state, when a low level on the ResetL pin is held for longer than the minimum pulse length. During the execution of a reset the host shall disregard all status bits until it indicates a completion of the reset interrupt. The product indicates this by posting an IntL (Interrupt) signal with the Data\_Not\_Ready bit negated in the memory map. Note that on power up (including hot insertion) the module should post this completion of reset interrupt without requiring a reset.

Low Power Mode (LPMode) pin is used to set the maximum power consumption for the product in order to protect hosts that are not capable of cooling higher power modules, should such modules be accidentally inserted.

Module Present (ModPrsL) is a signal local to the host board which, in the absence of a product, is normally pulled up to the host Vcc. When the product is inserted into the connector, it completes the path to ground through a resistor on the host board and asserts the signal. ModPrsL then indicates its present by setting ModPrsL to a "Low" state.

Interrupt (IntL) is an output pin. When Low" , it indicates a possible operational fault or a status critical to the host system. The host identifies the source of the interrupt using the 2-wire serial interface. The IntL pin is an open collector output and must be pulled to the Host Vcc voltage on the Host board.

### 3. Transceiver Block Diagram

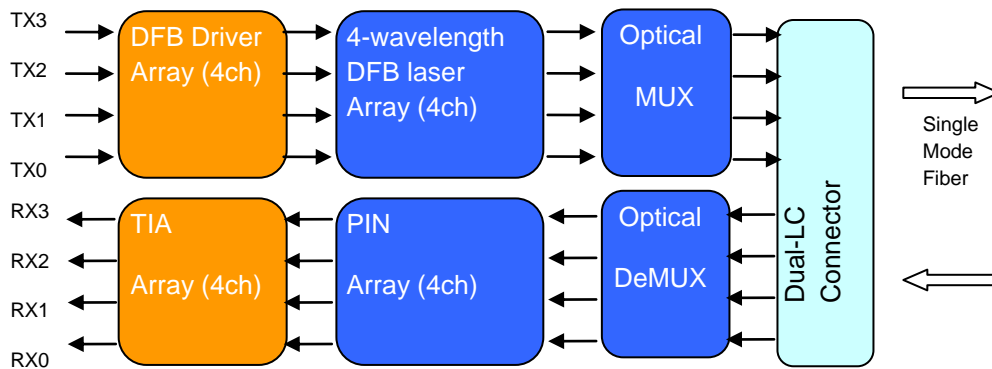

**Figure 1: 40Gb/s QSFP IR4 Transceiver Block Diagram**

#### 4. Pin Assignment and Pin Description

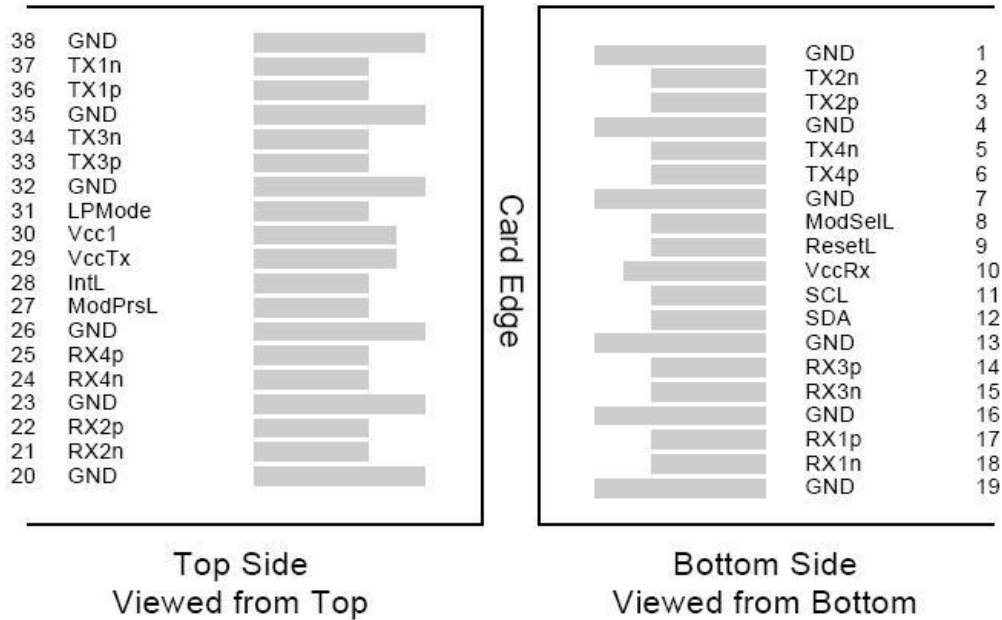

Figure 2: MSA compliant Connector

#### 5. Pin Definition

PIN	Logic	Symbol	Name/Description	Note
1		GND	Ground	1
2	CML-I	Tx2n	Transmitter Inverted Data Input	
3	CML-I	Tx2p	Transmitter Non-Inverted Data output	
4		GND	Ground	1
5	CML-I	Tx4n	Transmitter Inverted Data Input	
6	CML-I	Tx4p	Transmitter Non-Inverted Data output	
7		GND	Ground	1
8	LVTLL-I	ModSelL	Module Select	
9	LVTLL-I	ResetL	Module Reset	
10		VccRx	+ 3.3V Power Supply Receiver	2
11	LVC MOS-I/O	SCL	2-Wire Serial Interface Clock	
12	LVC MOS-I/O	SDA	2-Wire Serial Interface Data	
13		GND	Ground	
14	CML-O	Rx3p	Receiver Non-Inverted Data Output	
15	CML-O	Rx3n	Receiver Inverted Data Output	
16		GND	Ground	1
17	CML-O	Rx1p	Receiver Non-Inverted Data Output	

18	CML-O	Rx1n	Receiver Inverted Data Output	
19		GND	Ground	1
20		GND	Ground	1
21	CML-O	Rx2n	Receiver Inverted Data Output	
22	CML-O	Rx2p	Receiver Non-Inverted Data Output	
23		GND	Ground	1
24	CML-O	Rx4n	Receiver Inverted Data Output	1
25	CML-O	Rx4p	Receiver Non-Inverted Data Output	
26		GND	Ground	1
27	LVTTTL-O	ModPrsL	Module Present	
28	LVTTTL-O	IntL	Interrupt	
29		VccTx	+3.3 V Power Supply transmitter	2
30		Vcc1	+3.3 V Power Supply	2
31	LVTTTL-I	LPMODE	Low Power Mode	
32		GND	Ground	1
33	CML-I	Tx3p	Transmitter Non-Inverted Data Input	
34	CML-I	Tx3n	Transmitter Inverted Data Output	
35		GND	Ground	1
36	CML-I	Tx1p	Transmitter Non-Inverted Data Input	
37	CML-I	Tx1n	Transmitter Inverted Data Output	
38		GND	Ground	1

**Note:**

1. GND is the symbol for signal and supply (power) common for QSFP modules. All are common within the QSFP module and all module voltages are referenced to this potential unless otherwise noted. Connect these directly to the host board signal common ground plane.

2. VccRx, Vcc1 and VccTx are the receiving and transmission power suppliers and shall be applied concurrently. Recommended host board power supply filtering is shown below. Vcc Rx, Vcc1 and Vcc Tx may be internally connected within the QSFP transceiver module in any combination. The connector pins are each rated for a maximum current of 500mA.

## 6. Absolute Maximum Ratings

It has to be noted that the operation in excess of any individual absolute maximum ratings might cause permanent damage to this module.

Parameter	Symbol	Min	Max	Unit	Note
Storage Temperature	Tst	-40	85	degC	
Operating Case Temperature	Topc	20	65	degC	
Operating Range		0.002	2	km	
Supply Voltage	VCC	3.15	3.47	V	

## 7. Optical Characteristics

Parameter	Symbol	Min.	Typical	Max	Unit	Notes
Wavelength Assignment	L0	1264.5	1271	1277.5	nm	
	L1	1284.5	1291	1297.5	nm	
	L2	1304.5	1311	1317.5	nm	
	L3	1324.5	1331	1337.5	nm	
<b>Transmitter</b>						
Side-mode Suppression Ratio	SMSR	30	-	-	dB	
Total Average Launch Power	P <sub>T</sub>	-	-	8.3	dBm	
Optical Modulation Amplitude, each Lane	OMA	-2	-	+3.5	dBm	
Difference in Launch Power between any two Lanes (OMA)		-	-	5	dB	
Extinction Ratio	ER	3.5	-	-	dB	
Relative Intensity Noise	R <sub>in</sub>	-	-	-128	dB/Hz	12dB reflection
-20dB Spectral Width		-	-	1	nm	Modulated
Transmitter Reflectance	R <sub>T</sub>			-12	dB	

Total Jitter				0.2	UI	
Transmitter Eye Mask Definition {X1, X2, X3, Y1, Y2, Y3}		{0.25, 0.4, 0.45, 0.25, 0.28, 0.4}				
Transmitter Output Power Monitoring Accuracy	OPMA	-2		2	dB	
<b>Receiver</b>						
Damage Threshold	TH <sub>d</sub>	3.5			dBm	1
Receiver Sensitivity, each Lane	S <sub>R</sub>	-	-	-11.5	dBm	
Difference in Receive Power between any two Lanes (OMA)				7.5	dB	
Receive Electrical 3 dB upper Cutoff Frequency, each Lane				12.3	GHz	
RSSI Accuracy		-2		2	dB	

**Notes:**

1. The receiver shall be able to tolerate, without damage, continuous exposure to a modulated optical input signal having this power level on one lane. The receiver does not have to operate correctly at this input power.
2. Vertical eye closure penalty and stressed eye jitter are test conditions for measuring stressed receiver sensitivity. They are not characteristics of the receiver.

## 8. Electrical Characteristics

The following electrical characteristics are defined over the Recommended Operating temperature and supply voltage unless otherwise specified.

Parameter	Symbol	Min.	Typical	Max	Unit	Notes
Supply Voltage	V <sub>ccI</sub> , V <sub>ccTx</sub> , V <sub>ccRx</sub>	-0.5	-	3.6	V	
Data Rate, each Lane		-	10.3125	11.2	Gbps	
<b>Transmitter</b>						
Differential Input Impedance		85	100	115	ohm	
Differential Input Swing		150		1200	mV	
Differential Return Loss	Compliant to IEEE 802.3ba				dB	
<b>Receiver</b>						
Differential Output Impedance		85	100	115	ohm	
Differential Output Swing		370		950	mV	
Receiver J9 Jitter				0.65	UI	
Receiver electrical mask	Compliant to IEEE 802.3ba					
Output differential return Loss	Compliant to IEEE 802.3ba				dB	

## 9. Mechanical Dimensions

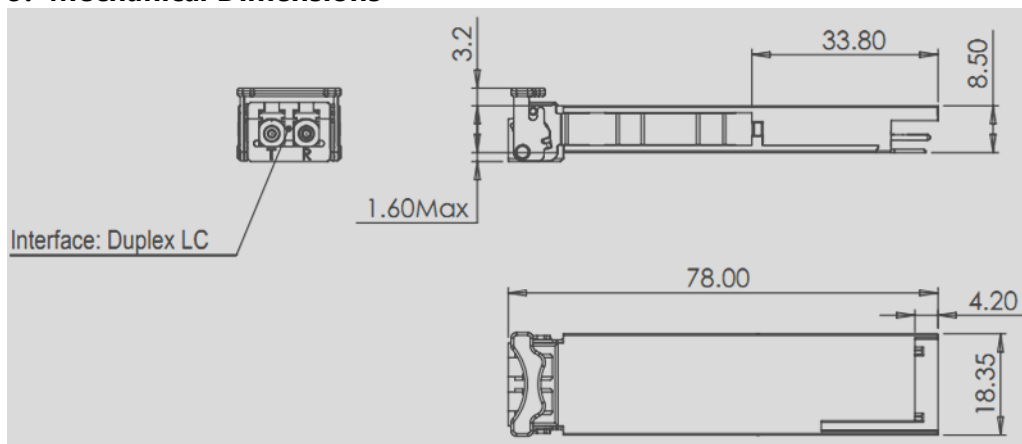



**10. ESD**

This transceiver is specified as ESD threshold 1kV for SFI pins and 2KV for all others electrical input pins, tested per MIL-STD-883, Method 3015.4 /JESD22-A114-A (HBM). However, normal ESD precautions are still required during the handling of this module. This transceiver is shipped in ESD protective packaging. It should be removed from the packaging and handled only in an ESD protected environment.

**11. Laser Safety**

This is a Class 1 Laser Product according to IEC 60825-1:1993:+A1:1997+A2:2001. This product complies with 21 CFR 1040.10 and 1040.11 except for deviations pursuant to Laser Notice No. 50, dated (June 24, 2007)

USA	China
InnoLight Technology Corp. Tel: (408) 598-4238 Fax: (408) 598-4201 Email: omok@innolight.com  Address: 1237 East Arques Avenue, Sunnyvale, CA 94085	InnoLight Technology (Suzhou) Ltd. Tel: (0512) 8666-9288 Fax: (0512) 8666-9299 Email: <a href="mailto:sales@innolight.com">sales@innolight.com</a> Address: 328 Xinghu Street,12-A3, Suzhou Industrial Park, Suzhou, Jiangsu Province, 215123, China

**Contact Information**