

SFP+ ZR DWDM Optical Transceiver Module
TR-GXxxZ-N00
10GBASE-ZR/ZW, up to 80km SMF Transmission
(Preliminary)

Features

- 10Gb/s serial optical interface compliant to 802.3ae 10GBASE-ZR/ZW
- Electrical interface compliant to SFF-8431 specifications for enhanced 8.5 and 10 Gigabit small form factor pluggable module "SFP+"
- 2-wire interface for management specifications compliant with SFF 8472 digital diagnostic monitoring interface for optical transceivers
- Operating case temperature: 0 to 70 °C
- All-metal housing for superior EMI performance
- Low power consumption, less than 1.6 w
- Advanced firmware allow customer system encryption information to be stored in transceiver
- Cost effective SFP+ solution, enables higher port densities and greater bandwidth
- RoHS compliant



Applications

- 10GBASE-ZR/ZW
- 10GBASE-ZR/ZW + FEC
- 10G Storage system

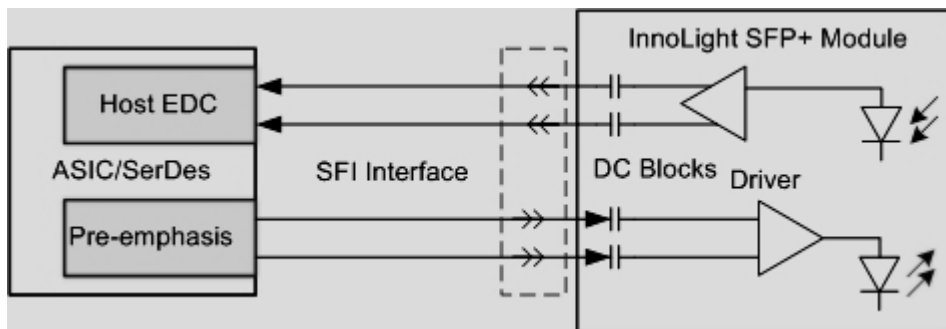

Figure1: Application in System

1. GENERAL DESCRIPTION

This cooled EML laser based 10Gigabit SFP+ transceiver is designed to transmit and receive optical data over single mode optical fiber for link length up to 80km.

The SFP+ ZR DWDM module electrical interface is compliant to SFI electrical specifications. The transmitter input and receiver output impedance is 100 Ohms differential. Data lines are internally AC coupled. The module provides differential termination and reduce differential to common mode conversion for quality signal termination and low EMI. SFI typically operates over 200 mm of improved FR4 material or up to about 150mm of standard FR4 with one connector.

The transmitter converts 10Gbit/s serial PECL or CML electrical data into serial optical data compliant with the 10GBASE-ZR standard. An open collector compatible Transmit Disable (Tx_disable) is provided. Logic "1" or no connection on this pin will disable the laser from transmitting. Logic "0" on this pin provides normal operation. The transmitter has an internal automatic power control loop (APC) to ensure constant optical power output across supply voltage and temperature variations. An open collector compatible Transmit Fault (Tx_Fault) is provided. TX_Fault is a module output that when high, indicates that the module transmitter has detected a fault condition related to laser operation or safety. The TX_Fault output is an open drain/collector and shall be pulled up to the Vcc_Host in the host with a resistor in the range 4.7-10 kΩ. TX_Disable is a module input contact. When TX_Disable is asserted high or left open, the SFP+ module transmitter output shall be turned off. This contact shall be pulled up to VccT with a 4.7 kΩ to 10 kΩ resistor

The receiver converts 10Gbit/s serial optical data into serial PECL/CML electrical data. An open collector compatible Loss of Signal is provided. Rx_LOS when high indicates an optical signal level below that specified in the relevant standard. The Rx_LOS contact is an open drain/collector output and shall be pulled up to Vcc_Host in the host with a resistor in the range 4.7-10 kΩ, or with an active termination. Power supply filtering is recommended for both the transmitter and receiver. The Rx_LOS signal is intended as a preliminary indication to the system in which the SFP+ is installed that the received signal strength is below the specified range. Such an indication typically points to non-installed cables, broken cables, or a disabled, failing or a powered off transmitter at the far end of the cable.

2. PROPOSED APPLICATION SCHEMATICS

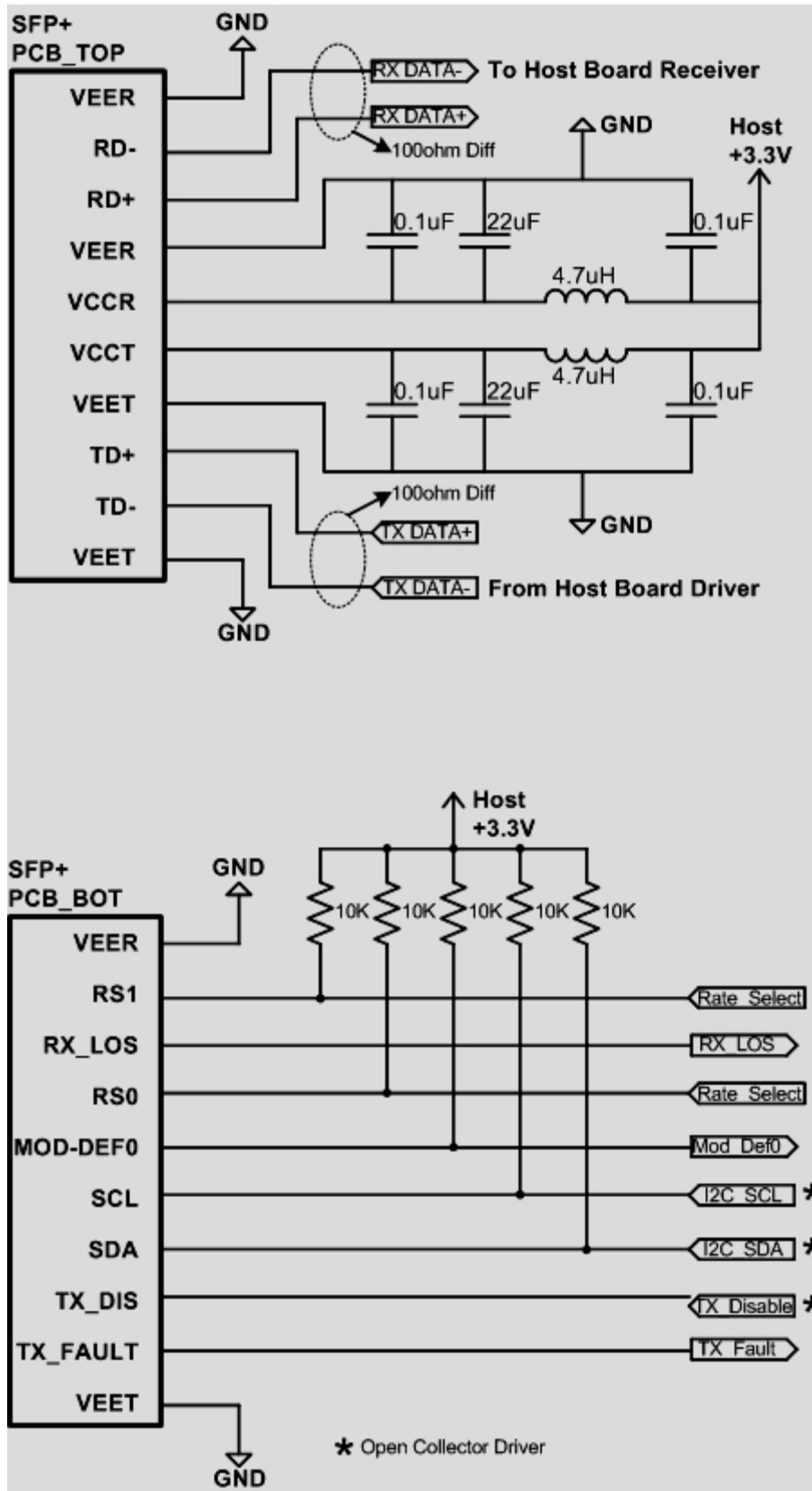

3. PIN DEFINITION

The SFP+ modules are hot-pluggable. Hot pluggable refers to plugging in or unplugging a module while the host board is powered. The SFP+ host connector is a 0.8 mm pitch 20 position right angle improved connector specified by SFF-8083, or stacked connector with equivalent with equivalent electrical performance. Host PCB contact assignment is shown in Figure 2 and contact definitions are given in Table 2. SFP+ module contacts mates with the host in the order of ground, power, followed by signal as illustrated by Figure 3 and the contact sequence order listed in Table 2.

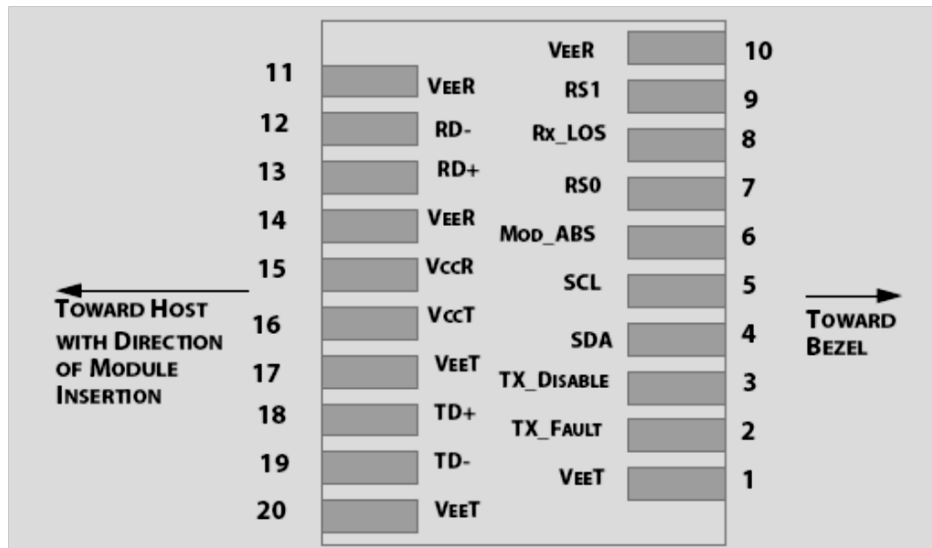

Figure 2: Module Interface to Host

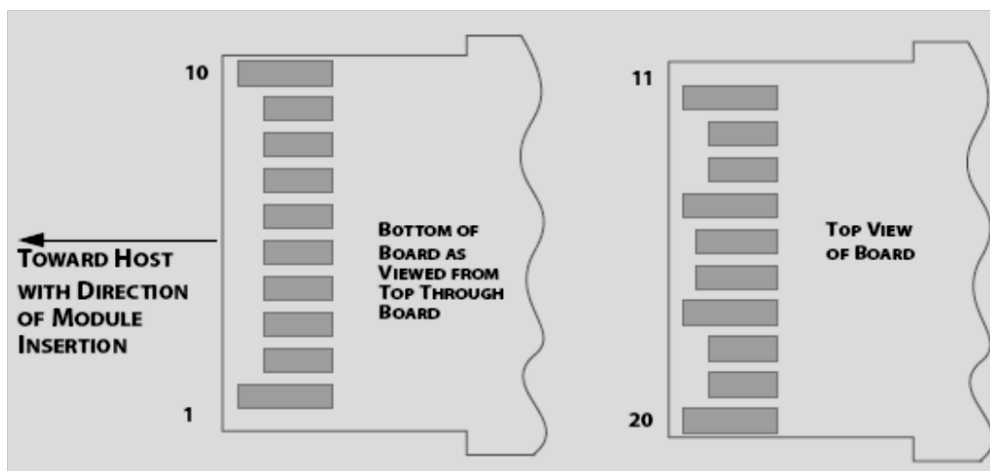

Figure 3: Module Contact Assignment

Table 1: SFP+ Module PIN Definition

PIN	Logic	Symbol	Name / Description	Note
1		VeeT	Module Transmitter Ground	1
2	LVTTL-O	TX_Fault	Module Transmitter Fault	
3	LVTTL-I	TX_Dis	Transmitter Disable; Turns off transmitter laser output	
4	LVTTL-I	SCL	2-Wire Serial Interface Clock	2
5	LVTTL-I/O	SDA	2-Wire Serial Interface Data Line	2
6		MOD_DEF0	Module Definition, Grounded in the module	
7	LVTTL-I	RS0	Receiver Rate Select	
8	LVTTL-O	RX_LOS	Receiver Loss of Signal Indication Active High	
9	LVTTL-I	RS1	Transmitter Rate Select	
10		VeeR	Module Receiver Ground	1
11		VeeR	Module Receiver Ground	1
12	CML-O	RD-	Receiver Inverted Data Output	
13	CML-O	RD+	Receiver Data Output	
14		VeeR	Module Receiver Ground	1
15		VccT	Module Receiver 3.3 V Supply	
16		VccT	Module Receiver 3.3 V Supply	
17		VeeT	Module Transmitter Ground	1
18	CML-I	TD-	Transmitter Inverted Data Input	
19	CML-I	TD+	Receiver Non-Inverted Data Output	
20		VeeT	Module Transmitter Ground	1

Note:

1. Module ground pins GND are isolated from the module case.
2. Shall be pulled up with 4.7-10Kohms to 3.15V~3.45V voltage on the host board.

4. TRANSCEIVER BLOCK DIAGRAM

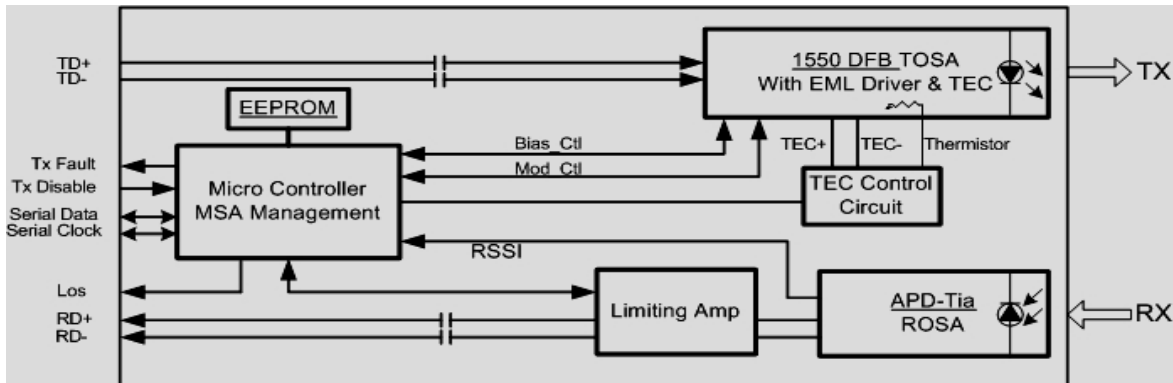

5. ABSOLUTE MAXIMUM RATING

These values represent the damage threshold of the module. Stress in excess of any of the individual Absolute Maximum Ratings can cause immediate catastrophic damage to the module even if all other parameters are within Recommended Operating Conditions.

Table 2: Absolute Maximum Rating

Parameters	Symbol	Min.	Max.	Unit
Power Supply Voltage	V _{CC}	0	3.6	V
Storage Temperature	T _c	-40	85	°C
Operating Case Temperature	T _c	0	70	°C
Relative Humidity	RH	5	95	%
RX Input Average Power	P _{max}	-	1.5	dBm

6. RECOMMENDED OPERATING ENVIRONMENT

Recommended Operating Environment specifies parameters for which the electrical and optical characteristics hold unless otherwise noted.

Table 3: Recommended Operating Environment

Parameters	Symbol	Min.	Typical	Max	Unit
Power Supply Voltage	V _{CC}	3.135	3.3	3.465	V
Power Supply Current	I _{CC}		400	600	mA
Operating Case Temperature	T _c	0	25	70	°C

7. OPTICAL CHARACTERISTICS

The following optical characteristics are defined over the Recommended Operating Environment unless otherwise specified.

Table 4: Optical Characteristics

Transmitter Optical Interface						
Parameter	Symbol	Min	Typical	Max	Unit	Note
Operating Data Rate	-	9.95		11.30	Gb/s	1
Output Center	λ	Per ordering info			nm	

Wavelength						
SMSR	SMSR	35		-	dB	
Average Output Power	Po	0		+4	dBm	2
Disabled Power	Poff	-		-30	dBm	2
Extinction Ratio	ER	9.0	10	-	dB	2
Eye Mask1 (SONET/SDH)		GR-253-CORE/ITU-T G.691				2
Eye Mask 2 (10G Ethernet)		IEEE802.3ae				3
Center wavelength stability	$\Delta\lambda D$	-90		90	pm	
Spectral Width (-20dB from Peak)	FW20		0.25		nm	
Relative Intensity Noise	RIN	-		-130	dB/Hz	
Dispersion Penalty	DP			2	dB	4
Receiver Optical Interface						
Parameter	Symbol	Min	Typical	Max	Unit	Note
Operating Data Rate		9.95		11.30	Gb/s	1
Input Center Wavelength	Irc	1250		1620	nm	
Overload	Rovl	-7.0		-	dBm	
Minimum Sensitivity	Pmin	-	-	-24.0	dBm	2
LOS Assert	LOSA	-35			dBm	
LOS Deassert	LOSD			-28	dBm	
LOS Hysteresis	LOSH	0.5			dB	

Optical Return Loss	ORL	27		-	dB	
Jitter Tolerance	JTL	GR-253-CORE/ITU-T G.783				

Notes:

1. Average optical power shall be measured using the methods specified in TIA/EIA-455-95.
2. Receiver sensitivity is informative. Stressed receiver sensitivity shall be measured with conformance test signal for BER = 1×10^{-12} .
3. Path penalty is intended as the power penalty of the interface between back-to-back and the maximum applied dispersion.

8. DIGITAL DIAGNOSTIC FUNCTIONS

The following digital diagnostic characteristics are defined over the Recommended Operating Environment unless otherwise specified. It is compliant to SFF8472 Rev10.2 with internal calibration mode. For external calibration mode please contact our sales staff.

Table 5: Digital diagnostic specification table

Parameter	Symbol	Min.	Max	Unit	Notes
Temperature monitor absolute error	DMI_Temp	-3	3	degC	Over operating temp
Laser power monitor absolute error	DMI_TX	-3	3	dB	
RX power monitor absolute error	DMI_RX	-3	3	dB	-7dBm to -24dBm
Supply voltage monitor absolute error	DMI_VCC	-0.1	0.1	V	Full operating range
Bias current monitor	DMI_Ibias	-10%	10%	mA	

9. ELECTRICAL CHARACTERISTICS

The following electrical characteristics are defined over the Recommended Operating Environment unless otherwise specified.

Table 6: Electrical Characteristics

Parameter	Symbol	Min.	Typical	Max	Unit	Notes
Data Rate		9.95	10.3125	11.3	Gbps	NRZ
Power Consumption		-	1300	1800	mW	
Transmitter						
Single Ended Output Voltage Tolerance		-0.3	-	4	V	
Common mode voltage tolerance		15	-	-	mV	
Tx Input Diff Voltage	VI	180		700	mV	
Tx Fault	VoL	-0.3		0.4	V	At 0.7mA
Data Dependent Input Jitter	DDJ			0.1	UI	
Data Input Total Jitter	TJ			0.28	UI	
Receiver						
Single Ended Output Voltage Tolerance		-0.3	-	4	V	
Rx Output Diff Voltage	Vo	300		850	mV	
Rx Output Rise and Fall Time	Tr/Tf	30			ps	20% to 80%
Total Jitter	TJ			0.7	UI	
Deterministic Jitter	DJ			0.42	UI	

10. CONTROL AND STATUS I/O TIMING CHARACTERISTICS

Timing characteristics of control and status I/O are included in Table 7, which is also defined in SFF-8431.

Table 7: Timing Characteristics

Parameter	Symbol	Min	Max	Unit	Condition
TX_Disable assert time	t_off		100	Us	Rising edge of TX_Disable to fall of output signal below 10% of nominal
TX_Disable negate time	t_on		2	ms	Falling edge of TX_Disable to rise of output signal above 90% of nominal. This only applies in normal operation, not during start up or fault recovery
Time to initialize 2-wire interface	T_2w_start_up		300	ms	From power on or hot plug after the supply meeting Table 8
Time to Initialize	t_start_up		300	ms	From power supplies meeting Table8 or hot plug or Tx_disable negated during power up, or Tx_fault recovery. Until non-cooled power level 1 part (or non-cooled power level II part already enable at power level II for Tx_fault recovery) is fully operational
Time to initialize cooled module	t_start_up_cooled		90	s	From power supplies meeting Table8 or hot plug or Tx_disable negated during power up, or Tx_fault recovery. Until cooled power level 1 part (or cooled power level II part during fault recovery) is fully operational
Time to power up	t_power_lev		300	ms	From falling edge of stop bit enabling power level II until non-cooled

to Level II	el2				module is fully operational
Time to power down form Level II	t_power_down		300	ms	From falling edge of stop bit disabling power level II until module is within power level I requirements
TX_fault assert	TX_Fault_on		1	ms	From occurrence of fault to assertion of TX_fault
TX_fault assert for cooled module	TX_Fault_on_cooled		50	ms	From occurrence of fault to assertion of TX_fault
TX_fault Reset	t_reset	10		us	Time TX_Disable must be held high to reset TX_fault
RS0, RS1 rate select timing for FC	t_RS0_FC, RS1_FC		500	us	From assertion till stable output
RS0, RS1 rate select timing non FC	t_RS0, t_RS1		10	ms	From assertion till stable output
Rx_Los assert delay	t_los_on		100	us	From occurrence of loss of signal to assertion Rx_Los
Rx_Los negate delay	t_los_off		100	us	From occurrence of loss of signal to negate of Rx_Los

11. MECHANICAL

Comply with SFF-8432 rev. 5.0, the improved Pluggable form factor specification.

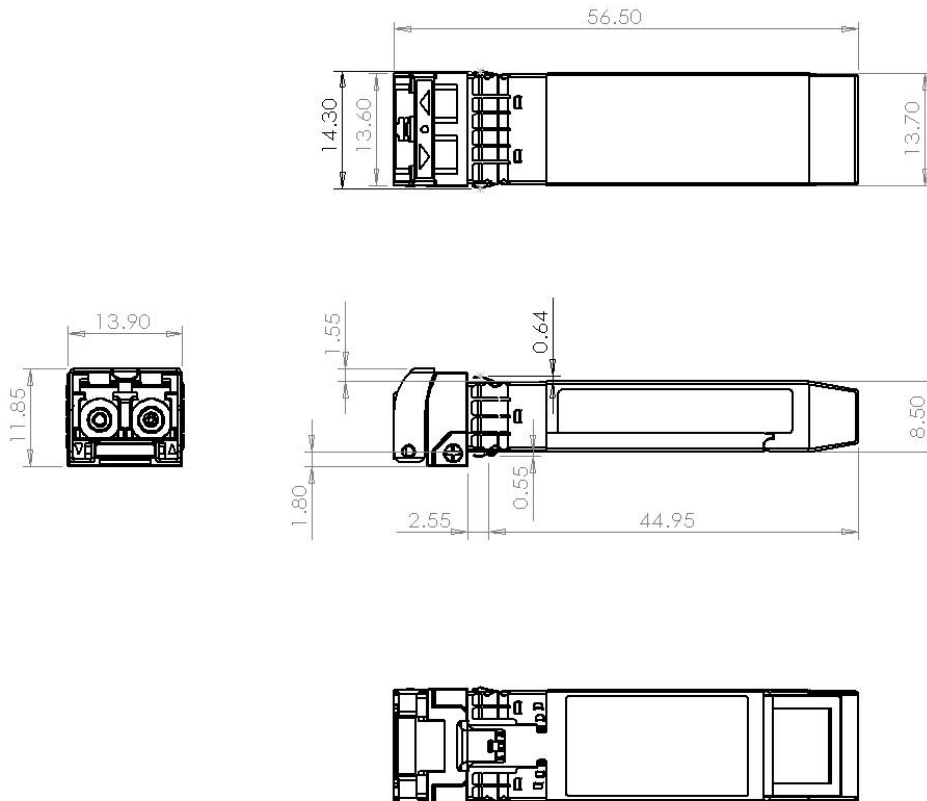

12. ESD

This transceiver is specified as ESD threshold 1kV for all electrical input pins, tested per MIL-STD-883G, Method 3015.4 /JESD22-A114-A (HBM). However, normal ESD precautions are still required during the handling of this module. This transceiver is shipped in ESD protective packaging. It should be removed from the packaging and handled only in an ESD protected environment.

13. LASER SAFETY

This is a Class 1 Laser Product according to IEC 60825-1:1993:+A1:1997+A2:2001. This product complies with 21 CFR 1040.10 and 1040.11 except for deviations pursuant to Laser Notice No. 50, dated (July 24, 2007)

14. Ordering Information

When ordering SFP+ module in the SFP+ product family, a 10-character suffix is used to fully specify the part number. The part number's suffix has 3 separate elements, as explained below.

Table 9: Named Information

TR	-	X	X	XX	X	-	X	XX
Optical Transceiver		Product Category G: SFP+ DWDM	Bit-rate X: 10Gb/s	Wavelength xx: DWDM Channel	Range Z: 40km		Temperature N: 0 to 70C	Customized Code 00:without CDR

Example

A part number of "TR-GX61Z-N00" represents a Fixed Channel 10Gb/s SFP DWDM module providing an 80km EML set to an ITU-T grid channel of 196.100THz on the 100GHz channel spacing.

Ordering Information - ITU grid wavelengths and frequencies are represented by the DWDM channel code xx field in the part number:

Table 10: Grid and Wavelength Information

Channel Code (xx)	Wavelength (nm)	Frequency (THz)
63	1527.22	196.30
62	1527.99	196.20
61	1528.77	196.10
60	1529.55	196.00
59	1530.33	195.90
58	1531.12	195.80
57	1531.90	195.70
56	1532.68	195.60
55	1533.47	195.50
54	1534.25	195.40
53	1535.04	195.30
52	1535.82	195.20

51	1536.61	195.10
50	1537.40	195.00
49	1538.19	194.90
48	1538.98	194.80
47	1539.77	194.70
46	1540.56	194.60
45	1541.35	194.50
44	1542.14	194.40
43	1542.94	194.30
42	1543.73	194.20
41	1544.53	194.10
40	1545.32	194.00
39	1546.12	193.90
38	1546.92	193.80
37	1547.72	193.70
36	1548.51	193.60
35	1549.32	193.50
34	1550.12	193.40
33	1550.92	193.30
32	1551.72	193.20
31	1552.52	193.10
30	1553.33	193.00
29	1554.13	192.90
28	1554.94	192.80
27	1555.75	192.70
26	1556.55	192.60
25	1557.36	192.50
24	1558.17	192.40
23	1558.98	192.30
22	1559.79	192.20
21	1560.61	192.10
20	1561.42	192.00
19	1562.23	191.90
18	1563.05	191.80
17	1563.86	191.70

USA	China
<p>InnoLight Technology Corp.</p> <p>Tel: (408) 838-8769</p> <p>Fax: (408) 777-8091</p> <p>Email: omok@innolight.com</p> <p>Address: 1237 East Arques Avenue. Sunnyvale, California 94089, USA</p>	<p>InnoLight Technology (Suzhou) Ltd.</p> <p>Tel: (0512) 8666-9288</p> <p>Fax: (0512) 8666-9299</p> <p>Email: sales@innolight.com</p> <p>Address:328 Xinghu Street, 12-A3, Suzhou Industrial Park, Suzhou, Jiangsu, 215123, China</p>

Contact Information