

2.1 Micron ASE Light Source

AP-ASE-2100

Amplified spontaneous emission (ASE), also called superluminescence, is the emission of fluorescence that is amplified along the gain media. AdValue Photonics' near 2.1 micron ASE source exhibits broad bandwidth with excellent spatial coherence and low temporal coherence.



Applications:

- Optical component testing
- Gas analysis
- Biomedical analysis
- Spectroscopy
- Research & development



Features:

- Broadest bandwidth
- Mid IR wavelength region
- High output power
- Diffraction limited beam quality
- Turn-key system with no maintenance

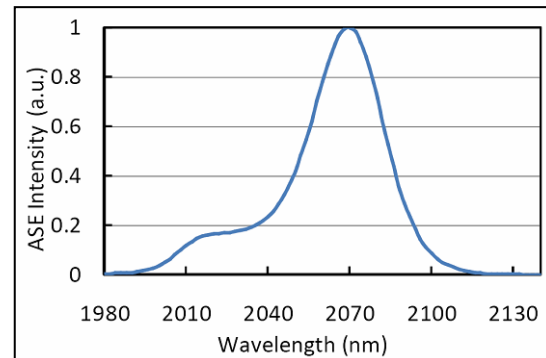

Optical Characteristics:

Parameter	Specification
Center wavelength	2.07±0.02 µm
Operation mode	CW
Output power (nominal)	10 mW
Bandwidth (-20dB)	>100 nm
Output power stability	±5% (at 25 °C)
Beam quality, M ²	< 1.1
Output polarization	Random
Output fiber and connector	SMF-28 single mode fiber, 3 mm jacket, 1 m length FC/APC connector

Specifications subject to change without notice

General Characteristics:

Parameter	Specification
Operating temperature	10 to +35 °C
Storage temperature	-10 to +65 °C
Cooling	Forced air
Power requirement	AC 100~240 V (50/60Hz)
Warm-up time	10 minutes
Package dimensions	448.6(W) x 433(D) x 132.5(H) mm

Mechanical Outline:

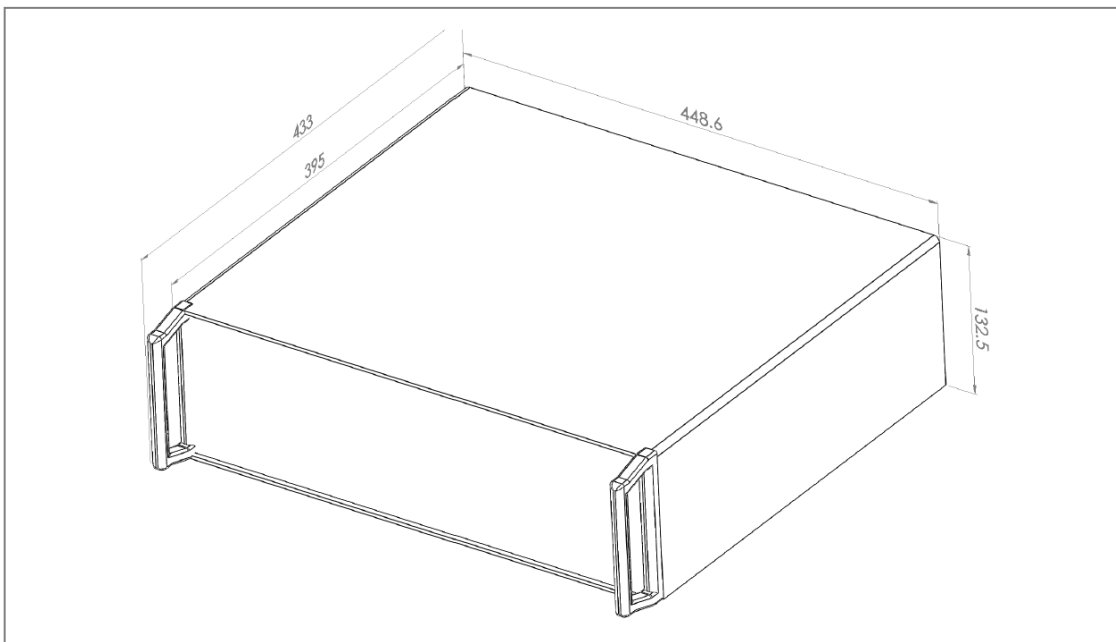

Ordering Information:

Part Number:	AP-ASE	-	2100	-	mxxx	-	(Polarization)
					Output Power: m010 = 10 mW		Polarization: (no spec) = random polarization

For special request, please contact us for more information at 1-520-790-5468 or sales@advaluephotonics.com.



Specifications subject to change without notice