

LD-1120-BA-6W	
High Power Diode Laser on open heatsink – 6W @ 1120nm	
	<p>Features:</p> <ul style="list-style-type: none"> • CW, quasi-CW operation • Proprietary mirror coating technology enabling high reliability • Reliable Au/Sn-bonding of chip to C-mount open heatsink • Burn-in test passed
	<p>Applications:</p> <ul style="list-style-type: none"> • Medical • Direct materials processing
Specification	DATE: 11 th Mar. 2010

SPECIFICATIONS				
Test conditions: heatsink temperature 25°C, output power 6W in CW operation				
Parameters	Min.	Typ.	Max.	Unit
Output power	6			W
Mean wavelength ¹	1110	1120	1130	nm
Wavelength temperature tunability	0.35	0.4	0.45	nm/°C
Spectral width (FWHM)		4	8	nm
Operating current		8	9	A
Threshold current		0.6	0.8	A
Forward voltage		1.3	1.5	V
Aperture size		130x1		µm ²
Divergence parallel to p-n junction (FWHM)	6	8	11	deg.
Divergence perpendicular to p-n junction (FWHM)	31	33	35	deg.

¹ Weighted mean ("center of mass") spectral point.

ABSOLUTE MAXIMUM RATINGS				
Parameters	Min.	Typ.	Max.	Unit
Lead soldering temperature		250 (5 sec.)		°C
Anode reverse voltage		1		V
Forward current			14	A
Storage temperature range (in original sealed pack)	5		80	°C
Operating temperature range	above dew point		60	°C

DIMENSIONS

All sizes in mm

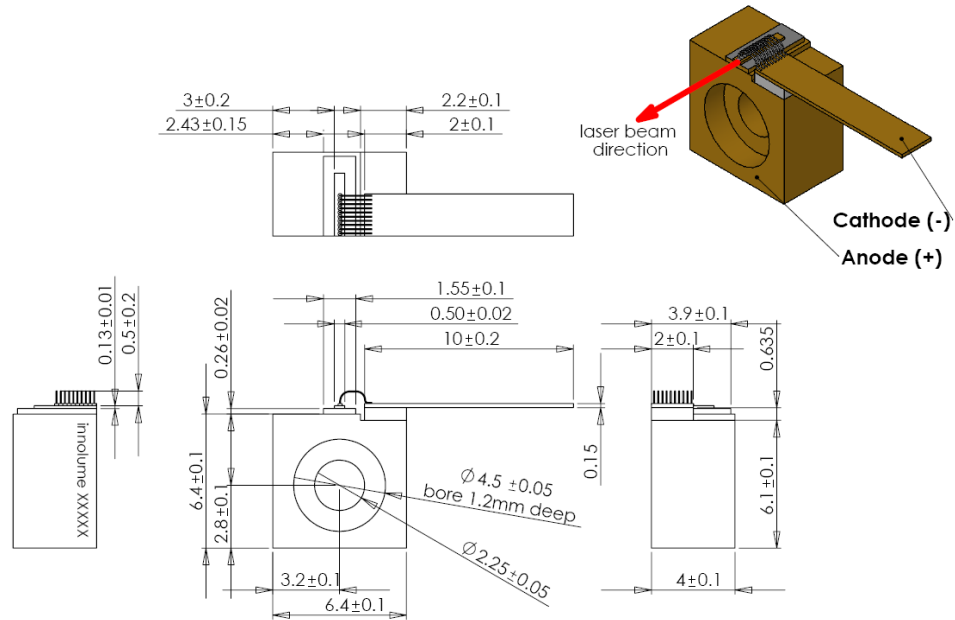

TYPICAL PERFORMANCE for reference only

CW, at 25°C heatsink temperature

Light-Current-Voltage Characteristics

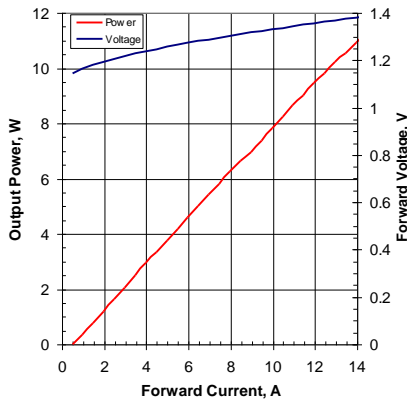

Spectra Characteristics

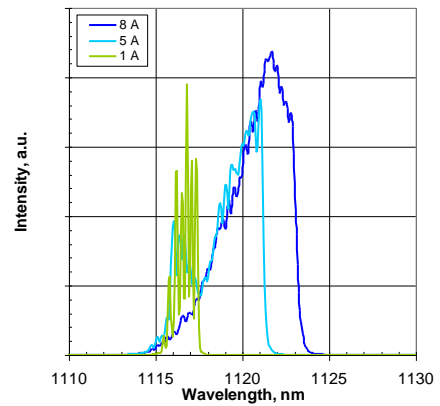

CW Slow Axis Far Field

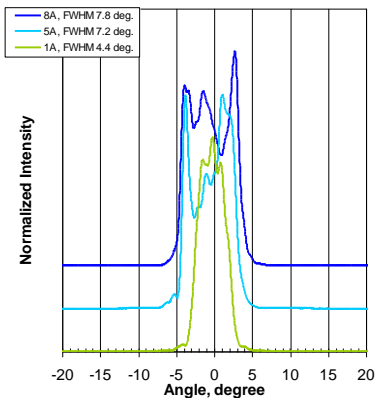

CW Fast Axis Far Field

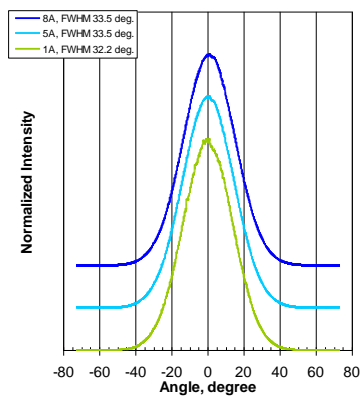

SAFETY AND OPERATING INSTRUCTIONS

The laser light emitted from this Device is invisible and will be harmful to the human eye. Avoid looking directly into the device output or into the collimated beam along its optical axis when the device is in operation. Proper laser safety eyewear must be worn during operation.

Absolute Maximum Ratings may be applied to the Device for short period of time only. Exposure to maximum ratings for extended period of time or exposure above one or more max ratings may cause damage or affect the reliability of the Device. Operating the product outside of its maximum ratings may cause device failure or a safety hazard. Power supplies used with the Device must be employed such that the maximum peak optical power cannot be exceeded. A proper heatsink for the Device on thermal radiator is required, sufficient heat dissipation and thermal conductance to the heatsink must be ensured.

The Device is an Open-Heatsink Diode Laser; it may be operated in cleanroom atmosphere or dust-protected housing only. Operating temperature and relative humidity must be controlled to avoid water condensation on the laser facets. Any contamination or contact of the laser facet must be avoided.

ESD PROTECTION – Electrostatic discharge is the primary cause of unexpected product failure. Take extreme precaution to prevent ESD. Use wrist straps, grounded work surfaces and rigorous antistatic techniques when handling the product.



NOTE: Innolume product specifications are subject to change without notice.