

OtO Photonics

EagleEye™ Series Product Sheet



Description

EE (EagleEye™) Series spectrometer, built with the Thermal Electric Cooler (TEC) sensor and high performance 32bits RISC controller in, is specially designed for long time measurement requirement. EE series contains a Thermal Electric Cooler (TEC) along with cooling system design to reduce dark current and maintain a lower stable operating temperature.

The optical engine is very simple and optimized for the spectrometer. The optical bench is very rigid and stable for measurement system, especially EE series has outstanding stability of thermo-hygro variation, vibration and shock on resolution and wavelength shift performance.

EE Series spectrometer is constructed by the Czerny-Turner optical design and can provide the high optical resolution, high sensitivity, low stray light, and fast spectral response.

The electronics system is powered by USB port and EE Series communicates with the PC through the USB port. Cooling system is supported by additional 5V DC power supply. It also provides 6 I/Os for external interface extension.

EE Series electronics operation is controlled by the RISC controller. Therefore, users can communicate to the main program through the PC software and the protocol provided by OtO Photonics.



- This Document is for business promotion use only.
- For customer's Specification Approval or IQC need, we will provide official Approval Sheet.

EE Series-206 Rev.1
www.otophotonics.com

OtO Photonics

EE Series Product Sheet

Attention

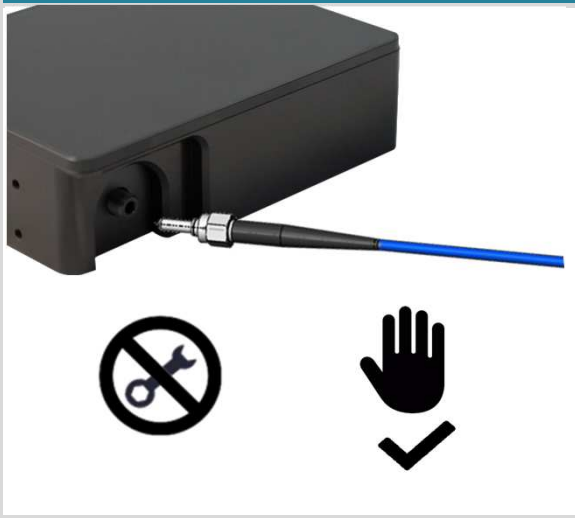
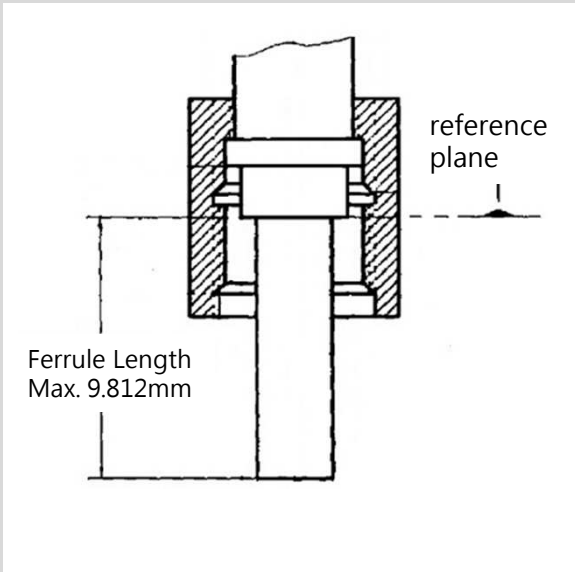
Picture	Description
	<p>To prevent over tightening and <u>damaging of the slit</u> in the spectrometer. Please <u>Hand tightening</u> the optical fiber only. Do not use any tool including wrench to tighten up the optical fiber and SMA905 connector.</p> <p>Apply adhesive to optical fiber connector after hand tightening is recommended if the fiber needs to be fixed robustly for a long time operation.</p>
	<p>Due to the design of SMA905 connector of spectrometer is based on <u>IEC 874-2:1993</u> and to prevent <u>damaging of the slit</u> in the spectrometer, please note the ferrule length of SMA905 Optical fiber must shorter than 9.812mm.</p>



OtO Photonics

EE Series Product Sheet

■	Overview	
1.1	Lineup of EE Series / Grating Table and Resolution	P4
1.2	Efficiency Output	P5
■	Main Features	
2.1	Feature	P6
2.2	Specification	P7
■	Structure	
3.1	Mechanical Diagram	P9
3.2	Electrical Pinout	P11
3.3	Detector Overview	P13
■	Internal Operation	P16
■	USB Port Interface Communications and Control Information	P18

OtO Photonics

EE Series Product Sheet

Overview

1.1 Lineup of EE Series

Model	Spectral Response Range (nm)				SNR ^{*1}	Dynamic Range ^{*2}	A/D	Stray Light	Thermal Stability
	FUVN	DUVN	NIR1	NIR4					
	180 ~ 1100	200 ~ 1025	790 ~ 1010	790 ~ 1090					
EE2051 EE2053 EE2111 EE2113			√	√	500	4700	16 bits	<0.45%	<0.015nm/°C
EE2063	√	√			500	4096			<0.04nm/°C

*1 : Single acquisition

*2 : 65535/Dark Noise(average)

EE2051	● NIR (800~1100nm) enhanced back-thinned TEC sensor
EE2053	● Best wavelength range for applications: 500~1100nm
EE2111	● Best choice for Raman measurement
EE2113	
EE2063	● UV enhanced back-thinned TEC sensor
	● Best wavelength range for applications: 180~1100nm
	● Best choice for ellipsometer, thin film measurement & high-end LED test

OtO Photonics

EE Series Product Sheet

► 1.2 Efficiency Output

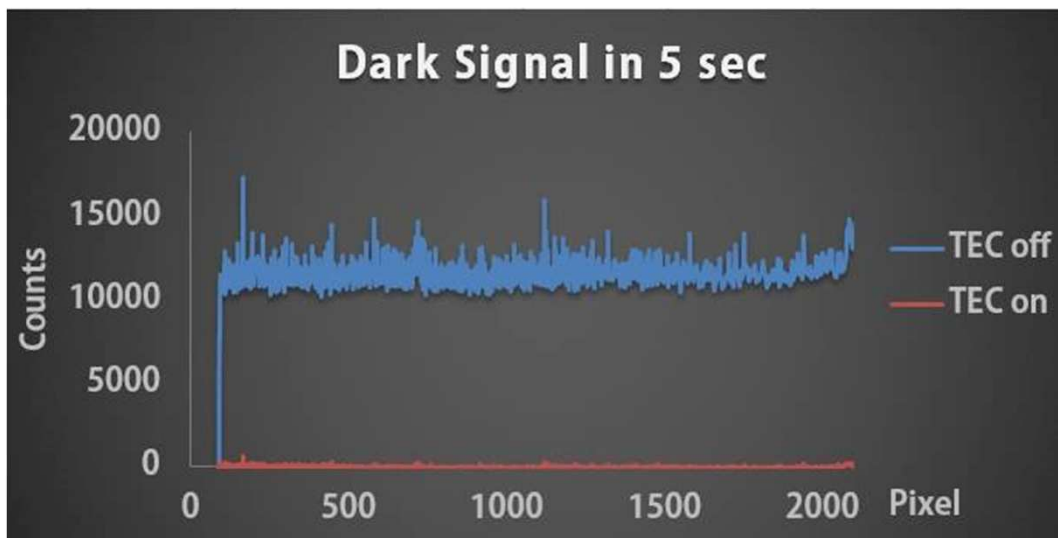
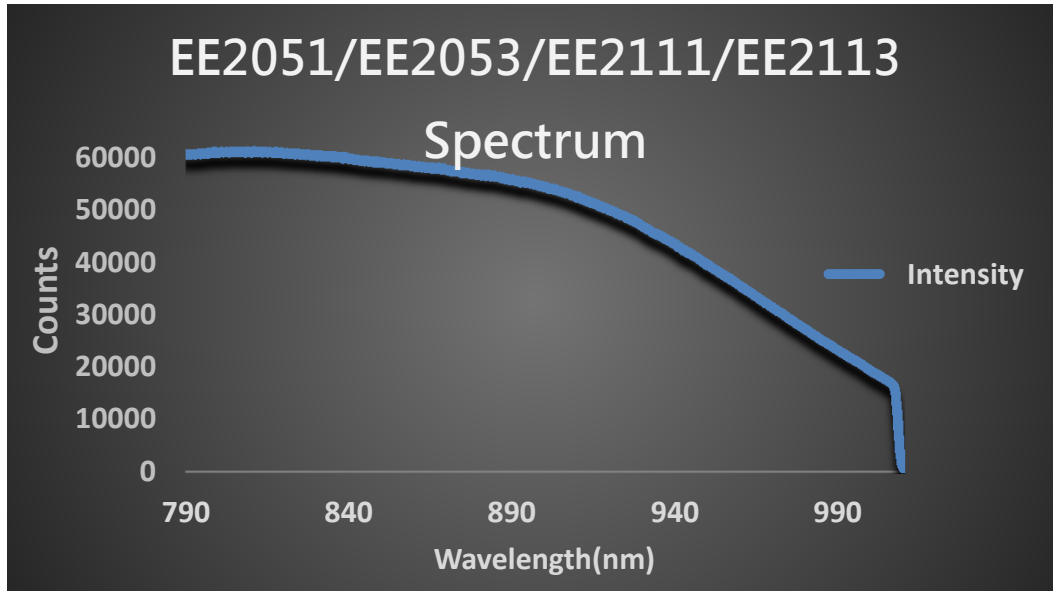

- This Document is for business promotion use only.
- For customer's Specification Approval or IQC need, we will provide office Approval Sheet.



OtO Photonics

EE Series Product Sheet

■ Main Features

▶ 2.1 Feature

- Responsive wavelength: from 180 to 1100 nm
- Optical resolution: 0.2 to 10.5 nm, depending on the combination of various slits and gratings.
- A variety of sensor can be chosen for specific application:
 - EE2051/EE2053/EE2111/EE2113: NIR Enhanced Back-Thinned 2048-pixel TEC linear sensor
 - EE2063 : UV Enhanced low noise type Back-Thinned 2048-pixel TEC linear sensor
 - Modular configuration with various grating, sensor, and slit options
- Integration times from 5 ms ~ 65 sec, depending on sensors
- 16 bit, 15MHz A/D Converter
- USB 2.0 @ 480 Mbps (High speed)
- 8-pin connector for interfacing to external
 - 6 user programmable digital I/O
- Plug-n-play interface for PC application
- Extremely precise continuous multiple exposures, providing up to 4,000 spectra buffering
- Flash ROM storage for
 - Wavelength Calibration Coefficients
 - Linearity Correction Coefficients
 - Intensity Calibration Coefficients

OtO Photonics

EE Series Product Sheet

► 2.2 Specification

SPEC	Content		
	EE2051/EE2111	EE2053/EE2113	EE2063
CCD*	HAMAMATSU S11511/S16011		HAMAMATSU S11850
	NIR-Enhanced Back thinned TEC sensor		UV-Enhanced Low noise type Back thinned TEC sensor
Dark Noise (Upper Limit)	20		25
Parameters of Optical System	f/# : 5, NA :0.1, Focal Length(R1-R2) :60-60 (It is recommended that the Incident NA should larger than the NA of spectrometer.)		
Dynamic Range (avg.)*1	4700:1		4000:1
SNR*2	500		500
CCD Cooling	Default : 0 ° C at Ambient of 25 ° C (cooling time: 1min)		
TEC Range	20 ° C- 25 ° C below ambient		
Spectrometer	EE series; Czerny-Turner Optical Structure 2 nd & 3 rd order rejection		
Dimension	130(L) x 86(W) x 31.5(H) mm	130(L) x 96(W) x 39.5(H) mm	130(L) x 96(W) x 39.5(H) mm
Grating	15 grating options ; spectral range from UV to NIR		
Slit Size	10, 25, 50, 100, 200,300 um		
Integration Time	5ms ~ 65sec, depending on sensors		
Wavelength accuracy	± 0.3 nm (Testing environment is based on EE2061-050-VNIR's parameter, and accuracy may be up to ± 1.0nm according to different environment such as severe temperature change and long-time vibration. OtO can offer free software for WL calibration if customer needed.)		

*1 : 65535/Dark Noise(average)

*2: Single acquisition

- This Document is for business promotion use only.
- For customer's Specification Approval or IQC need, we will provide office Approval Sheet.

OtO Photonics

EE Series Product Sheet

SPEC		Content		
		EE2051/EE2111	EE2053/EE2113	EE2063
Wavelength Repeatability		+/- 0.05 nm Continuous 100 measurements (Hg-Ar Light Source) OtO can offer free software for WL calibration if customer needed.)		
Resolution (FWHM)		From 0.2 nm to 10 .5 nm, depending on different modular configuration		
Thermal Stability		<0.04nm/ ° C (EE2063) <0.015nm/ ° C (EE2051)		
Environmental Conditions	Storage	-30°C to +70°C		
	Operation	0°C to +50°C		
	Humidity	0% - 90% non-condensing		
Interfaces		USB 2.0 @ 480 Mbps (High speed)		
Input Fiber Connector		SMA905: $\Phi 3.18 \pm 0.005 \text{mm}$		
		SMA905: $\Phi 3.20 \pm 0.01 \text{mm}$		
Power		Power requirement (USB): 330mA at +5 VDC DC Jack for TEC: 500mA at +5VDC Supply voltage: 4.75-5.25 Power-up time : < 4s Maximum USB input power Vcc : +5.25VDC Maximum I/O signal voltage : +5.5VDC		

- Customized design for your various special requirements including higher resolution, specific wavelength range, higher SNR, special gratings or sensors not in the list, specific software or hardware design, or special exposure modes, is welcome and will be elaborately built and tested by our R&D team.

- This Document is for business promotion use only.
- For customer's Specification Approval or IQC need, we will provide office Approval Sheet.

OtO Photonics

EE Series Product Sheet

Structure

3.1 Mechanical Diagram

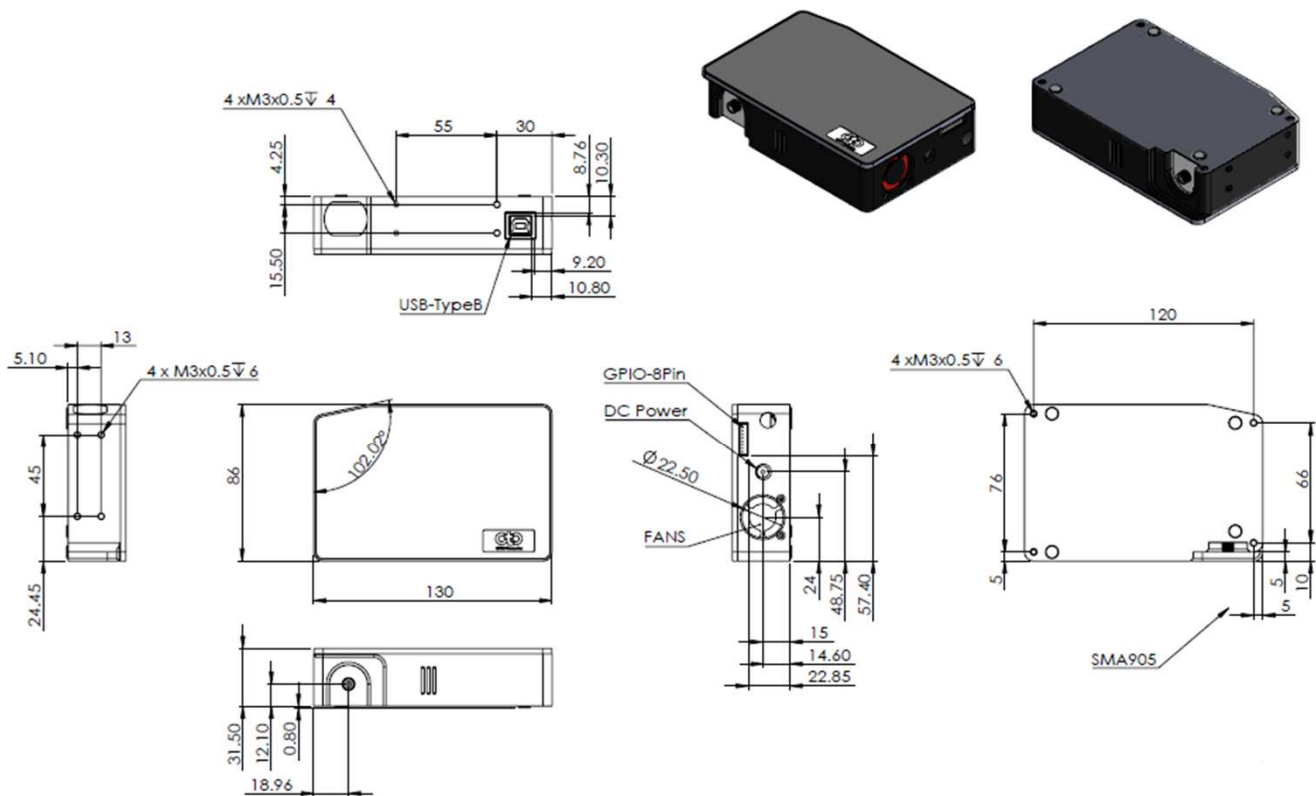

Fig. 1: EE2051/EE2111 outer dimensions

OtO Photonics

EE Series Product Sheet

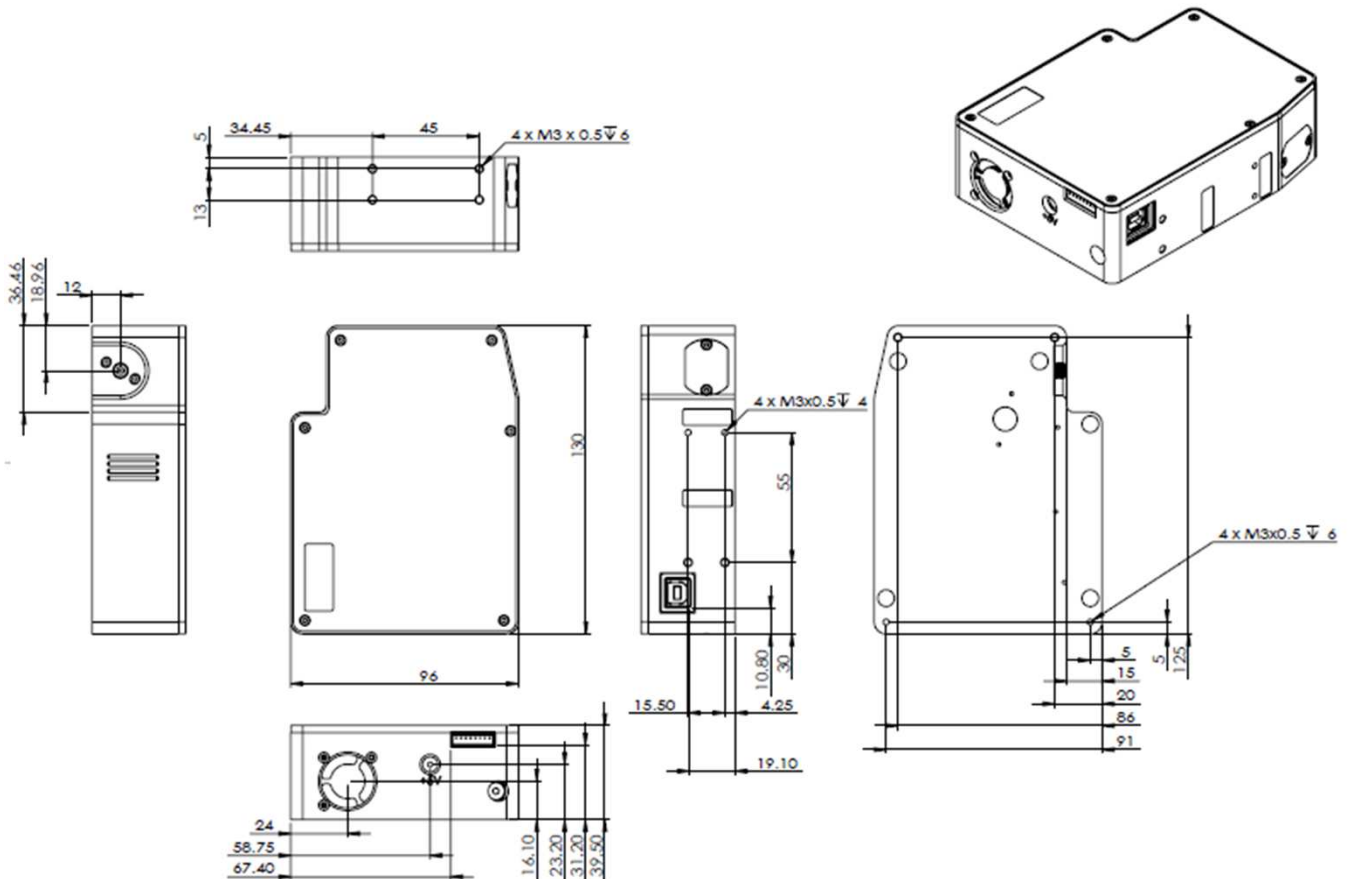

Fig. 2: EE2053/EE2113/EE2063 outer dimensions

OtO Photonics

EE Series Product Sheet

► 3.2 Electrical Pinout

The following list is the pin description for the EE Series Extension Connectors. The Back Extension Port is a 8 pin 2.0mm connector.

Side entry type

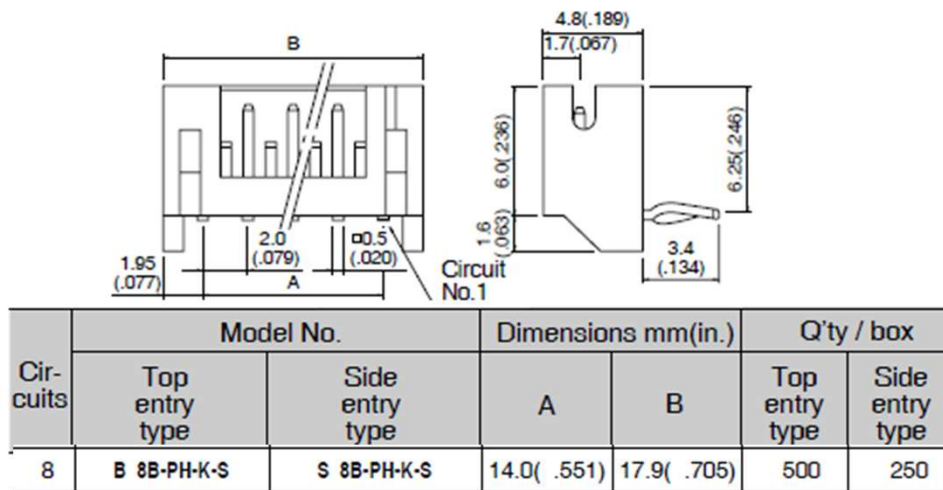

Fig. 3 : Back Extension Port 2.0 mm 8 pin drawing

OtO Photonics

EE Series Product Sheet

Back Extension Port Pin# Description Alt Function

*All I/Os are TTL-level input/output

Pin No.	Direction	Pin Name	Function Description
1	Power	5V Output	When connecting to PC USB port, this pin is also connected to VBUS. This pin can provide around 0.1A power for external device.
2	Output	TX	UART TX. TX is the output from the RISC controller.
3	Input	RX	UART RX. RX is the input for the RISC controller.
4	Output	GPIO0	General Purpose Output 0.
5	Output	GPIO1	General Purpose Output 1.
6	Output	LS_ON	Light Source Turn ON.
7	Input	Trigger_IN	External Trigger Input Signal.
8	GND	GND	GND

● Pin orientation

Looking at Front of EE Series connector side, from left to right are DC Jack and Back Extension Port.

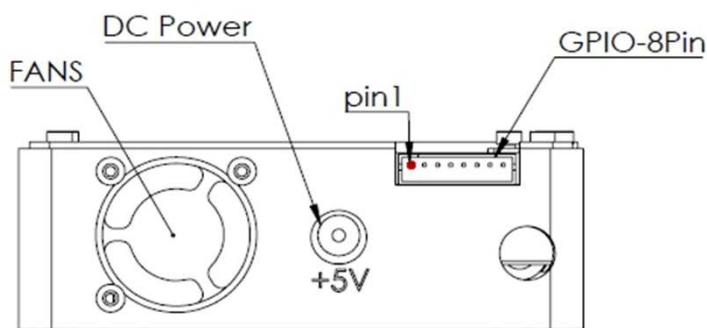

Fig. 4 : EE Series the front-view of connector mechanical graph

OtO Photonics

EE Series Product Sheet

► 3.3 Detector Overview

● TEC DETECTOR

TEC sensors are back-thinned CCD image sensors with high quantum efficiency from UV to near infrared region. A thermoelectric cooler is placed inside the package to keep the element temperature constant during operation.

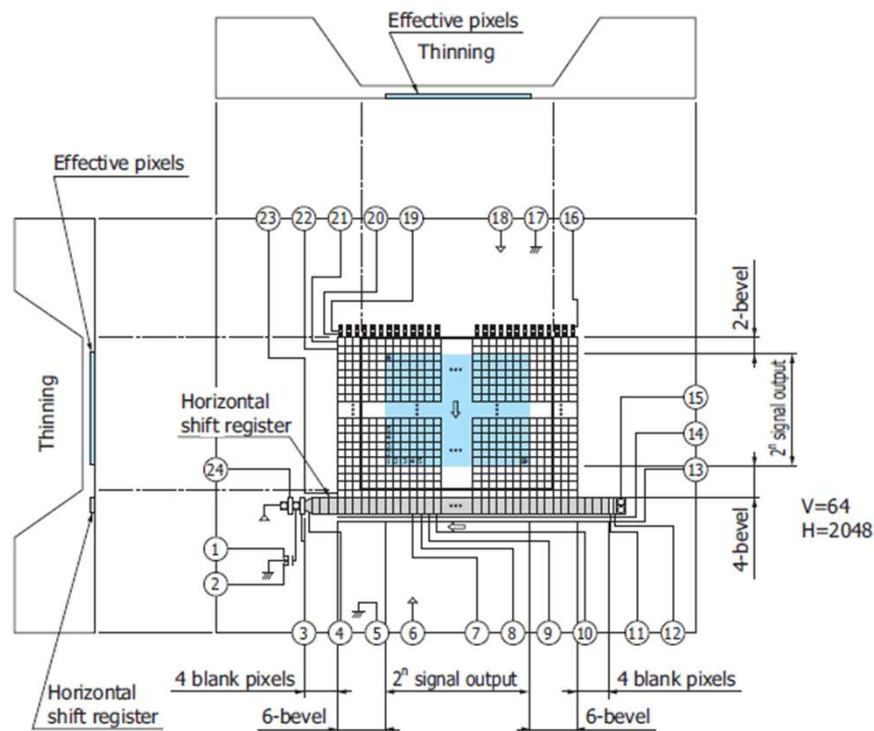

Fig. 5: TEC Sensor Block Diagram (S11850)



OtO Photonics

EE Series Product Sheet

- **Sensor/System Noise**

There are three major sources impact the Vout signal reading. One is the light source stability, the second is the electronics noise, and the other is detector noise. If we don't consider the outer light source influence, we can check the dark noise performance of this system first. The dark noise we define here is the RMS of Vout signal under 1ms or the shortest integration time in dark condition. So the dark noise will be only contributed by electronics readout noise and the sensor.

The other major parameter to define the noise performance is the SNR. The SNR we define here is the ratio of the full signal (65535 counts) to the RMS value under the full signal condition. The higher SNR performance indicates the readout signal is more stable. It will be helpful for the low signal differentiation.

- **Signal Averaging**

The software-SpectraSmart provides two options for the signal curve operations. The first one is the signal averaging. By the averaging method, we can reduce the noise impact on each pixel. Surely, more sampling points will bring the better averaging performance. But it will need more time to get one spectra. When we use the time-base type of signal averaging, the S:N increases by the square root of the number of samples. Thus, a S:N is readily 10x achieved by averaging 100 spectra.

The other curve smoothing is boxcar filter. It can average the adjacent points to show the smoother curve, but it will lower optical resolution. So if the target signal is peak type, the boxcar may not be suitable for this.

These two methods can be enabled at the same time if the measurement target is suitable for this operation. But if the user would like to check all the original data and performance, time-based average or boxcar smoothing needs to be un-checked. The default setting for these two average methods is un-checked.

OtO Photonics

EE Series Product Sheet

Internal Operation

4.1 Pixel Definition

The baseline signal is around 1,000 counts in our current system. We can provide the tool/command to manually adjust the baseline. (adjust the AFE OFFSET) The other baseline adjustment method is to enable the background removal from the software. It depends on the user how to use the baseline.

- The following is a description of all of the pixels

Pixel	Description
1–10	Dummy Pixel
11–2058	Optical active pixel
2059-2068	Dummy Pixel

4.2 Digital Inputs & Outputs

General Purpose Inputs/Outputs (GPIO)

EE Series has 6 user programmable 3.3V digital Input/Output pins, which can be accessed at the 8-pin Extension connector. Through software, the state of these I/O pins can be defined and used for multi-purpose applications. If the user needs the special timing generation (like single pulse or PWM), EE Series provides the flexibility to implement this.

OtO Photonics

EE Series Product Sheet

GPIO Recommended Operating Levels:

VIL(max) = 0.8V

VIH(min) = 2.0V

GPIO Absolute Maximum/Minimum Ratings are as follows:

VIN(min) = -0.3V

VIN(max) = 5.5V

● Communication and Interface

USB 2.0

480-Mbit **Universal Serial Bus** is the standard and popular communication interface in PC. Our PC software allows connecting multiple EE Series via USB and monitors multiple EE Series spectra.

● Extremely Precise Continuous Multiple Exposures

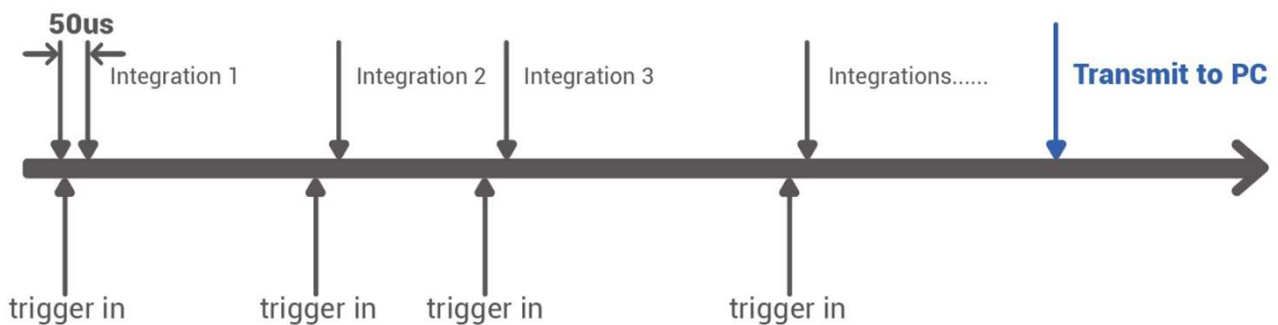

- ❑ Arbitrary integration times
- ❑ Spectra are stored in the huge memory on our board, providing up to 4000 spectra buffering
- ❑ After all integrations are done, the spectra are transmitted to your PC

- This Document is for business promotion use only.
- For customer's Specification Approval or IQC need, we will provide office Approval Sheet.



OtO Photonics

EE Series Product Sheet

■ USB Port Interface Communications and Control Information

▶ Overview

EE Series is a microcontroller-based Miniature Fiber Optic Spectrometer that can communicate via the Universal Serial Bus. This section contains the necessary programming information for controlling EE Series via the USB interface. This information is only pertinent to users who wish to not utilize SpectraSmart software to interface to EE Series.

● Hardware Description

EE Series utilizes a 32 bit RISC controller built in USB 2.0. Program code and data coefficients are stored in SPI Flash. The RISC controller supports 64 MByte DDR and 64 Mbits Flash.



OtO Photonics

EE Series Product Sheet

- **USB Info**

EE Series USB Vendor ID number is 0x0638 and the Product ID is 0x0AAC. EE Series is USB 2.0 compliance. The data exchange between host and spectrometer is via bulk streams. The detail USB information please refer USBIF @ <http://www.usb.org>.

- **INSTRUCTION SET**

Application Programming Interface

The list of the APIs is shown in the following table followed by a detailed description of each function call.

- **Open EE Series Spectrometer**

Description: To connect Windows host to EE Series

a.Function Name: UAI_SpectrometerOpen

b.Arguments:

dev: 8 EE Series spectrometers can be attached to one host at the same time. dev is the device number to specify which one will be opened.

handle: the unique Windows identifier to operate devices. Windows will return the identification number which is necessary for further operation.



OtO Photonics

EE Series Product Sheet

❑ Query Frame Size

Description: To get the data frame size of the spectrometer.

a.Function Name: UAI_SpectromoduleGetFrameSize

b.Arguments:

device_handle: a pointer to the device information structure which is returned

when device open.

size: a 16-bit unsigned integer will be returned to indicate the data length.

❑ Acquire Wavelength

Description: Initiates a wavelength acquisition. EE Series will acquire a complete wavelength distribution.

a.Function Name: UAI_SpectrometerWavelengthAcquire

b.Arguments:

device_handle: a pointer to the device information structure which is returned when

device open.

buffer: the storage buffer acquired data.



OtO Photonics

EE Series Product Sheet

□ Acquire Spectra

Description: Initiates a spectra acquisition. EE Series will acquire a complete intensity distribution which corresponds to the wavelength which is acquired by OtO_UAI_SpectrometerWavelengthAcquire.

a. **Function Name:** UAI_SpectrometerDataAcquire

b. **Arguments:**

device_handle: a pointer to the device information structure which is returned when device open.

integration_time_us: a 32-bit unsigned variable to determine the integration time of the micro-seconds.

buffer: the storage buffer acquired data.

average: the spectrum could be averaged by several continuous acquisitions to reduce the noise.

□ Query Wavelength Range

Description: To get the minimum and maximum wavelength

a. **Function Name:** UAI_SpectromoduleGetWavelengthStart

Function Name: UAI_SpectromoduleGetWavelengthEnd

b. **Arguments:**

device_handle: a pointer to the device information structure which is returned when device open.

lambda: a 32-bit floating type data which is indicate the minimum or maximum wavelength, in nm, of EE Series will be returned.



OtO Photonics

EE Series Product Sheet

❑ Query Integration Time Range

Description: To get the minimum and maximum integration time.

a.Function Name: UAI_SpectromoduleGetMinimumIntegrationTime

Function Name: UAI_SpectromoduleGetMaximumIntegrationTime

b. Arguments:

device_handle: a pointer to the device information structure which is returned when device open.

Integration Time: a 16-bit integer type data which indicates the minimum or maximum integration time of EE Series will be returned. The minimum integration time is in micro-second and the maximum Integration time is in milli-second.

❑ Close EE Series Spectrometer

Description: To connect Windows host to EE Series

a.Function Name: UAI_SpectrometerClose

b.Arguments:

handle: the unique Windows identifier to operate devices. Windows will detach

the device and any operation is invalid after this function is executed.