

OtO Photonics

HummingBird (HB) Series

Product sheet



Description

HB Series spectrometer is built with the linear CCD/COMS array sensor and 32bits RISC controller in. By simplification of the optical engine, the miniaturized spectrometer is achieved. External MB type of HB Series can be chosen to enhance heat dissipation. The compact size and various of screw holes is very flexible for system integration.

HB Series spectrometer is constructed by the Crossed Czerny-Turner optical design and can provide the high optical resolution, high sensitivity, low stray light, and fast spectral response.

The electronics system is powered by USB port and HB Series communicates with the PC through the USB port. It also provides 6 I/Os for external interface extension.

HB Series electronics operation is controlled by the RISC controller. So the user can communicate to the main program through the PC software and the protocol provided by OtO Photonics.



- This Document is for business promotion use only.
- For customer's Specification Approval or IQC need, we will provide official Approval Sheet.

OtO Photonics

HummingBird (HB) Series Datasheet

Attention

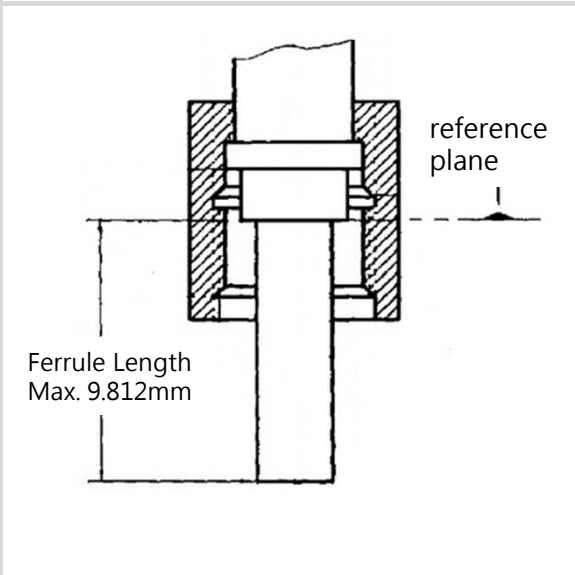
Picture	Description
	<p>To prevent over tightening and <u>damaging of the slit</u> in the spectrometer. Please <u>Hand tightening</u> the optical fiber only. Do not use any tool including wrench to tighten up the optical fiber and SMA905 connector.</p> <p>Apply adhesive to optical fiber connector after hand tightening is recommended if the fiber needs to be fixed robustly for a long time operation.</p>
	<p>Due to the design of SMA905 connector of spectrometer is based on <u>IEC 874-2:1993</u> and to prevent <u>damaging of the slit</u> in the spectrometer, please note the ferrule length of SMA905 Optical fiber must shorter than 9.812mm.</p>



OtO Photonics

HummingBird (HB) Series Datasheet

■ Overview

- | | | |
|-----|--|----|
| 1.1 | Lineup of HB Series / Grating Table and Resolution | P4 |
| 1.2 | Waveform Comparison | P5 |

■ Main Features

- | | | |
|-----|---------------|----|
| 2.1 | Feature | P6 |
| 2.2 | Specification | P7 |

■ Structure

- | | | |
|-----|--|-----|
| 3.1 | HBx034 Dual Cable, External M/B type, SMA905 | P9 |
| 3.2 | HBx054 & HBx094 External M/B type, SMA905 | P10 |
| 3.3 | HBx054 & HBx094 External M/B type, with out SMA905 | P11 |
| 3.4 | Electrical Pinout | P12 |
| 3.5 | CCD Overview | P15 |

■ Internal Operation

- | | | |
|-----|--------------------------|-----|
| 4.1 | Pixel Definition | P18 |
| 4.2 | Digital Inputs & Outputs | P18 |
| 4.3 | Trigger Mode | P20 |
| 4.4 | Ring Buffer | P23 |

- | | | |
|---|--|-----|
| ■ | USB Port Interface Communications and Control Information | P24 |
|---|--|-----|

OtO Photonics

HummingBird (HB) Series Datasheet

■ Overview

▶ 1.1 Lineup of HB Series

Model	Spectral Response Range (nm)					SNR ^{*1}	Dynamic Range ^{*2}	A/D	Stray Light	Thermal Stability
	FUVN	FUV	FUV2	NIR1	NIR4					
	180 λ 1100	180 λ 850	180 λ 500	790 λ 1010	790 λ 1090					
HB1034/ HB2034	√	√	√	√	√	330	5040 /4369	16 bits	<0.2%	<0.04nm/°C
HB1054/ HB2054				√	√	500	4370			
HB1094/ HB2094	√	√				500	2920			

*1 : Single acquisition

*2 : 65535/Dark Noise(average)

- This Document is for business promotion use only.
- For customer's Specification Approval or IQC need, we will provide office Approval Sheet.

OtO Photonics

HummingBird (HB) Series Datasheet

► 1.2 Waveform Comparison

Waveform of HB2034-050-NIR1 & NIR4

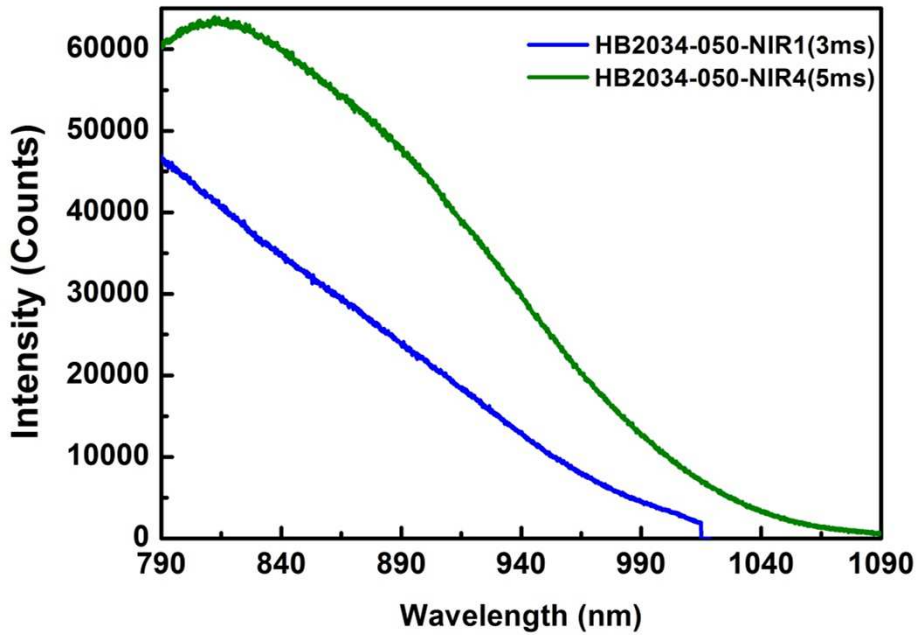

Waveform of HB2034-050-FUVN

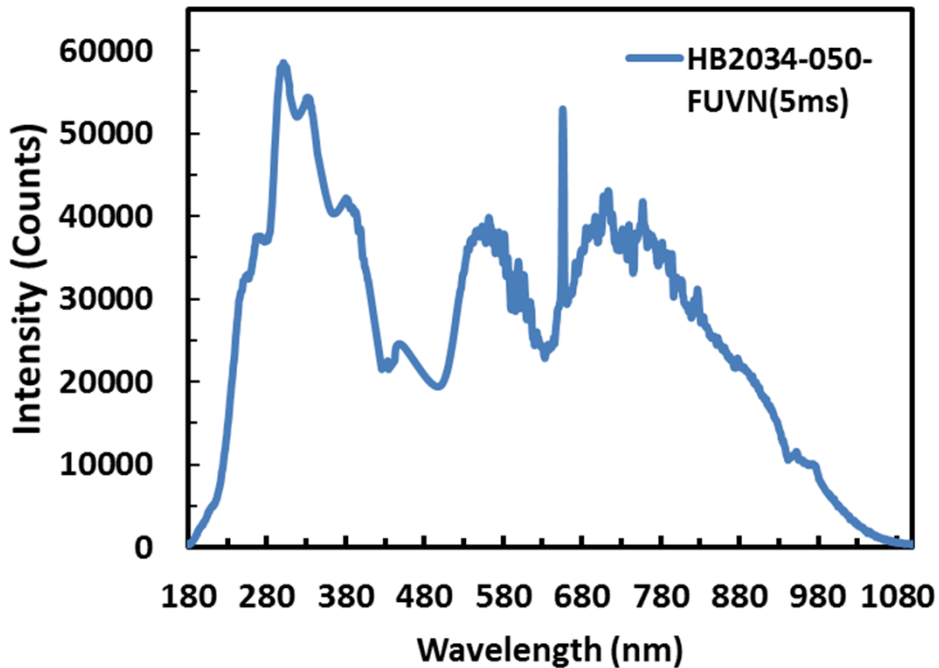



OtO Photonics

HummingBird (HB) Series Datasheet

■ Main Features

▶ 2.1 Feature

- Wavelength range: from 180 to 1100 nm
- Optical resolution: from 0.2 to 10.5nm, depending on the combination of various slits and gratings.
- A variety of sensor can be chosen for specific application:
 - ▣ High sensitivity 2048-pixel CMOS array sensor
 - ▣ Back-thinned NIR enhanced 2048-pixel CCD array sensor
- Modular configuration with various grating, sensor, and slit options
- Integration times from 0.2 ms to 65 seconds, depending on sensors
- 16 bit, 15MHz A/D Converter
- USB 2.0 @ 480 Mbps (High speed)
- 8-pin connector for interfacing to external
 - ▣ 6 user programmable digital I/O
- Plug-n-play interface for PC application
- Extremely precise continuous multiple exposures, providing up to 4,000 spectra buffering
- CCD clock rate can be adjusted to meet the demand of wavelength repeatability or processing speed.
- Flash ROM storage for
 - ▣ Wavelength Calibration Coefficients
 - ▣ Linearity Correction Coefficients
 - ▣ Intensity Calibration Coefficients

OtO Photonics

HummingBird (HB) Series Datasheet

► 2.2 Specification

SPEC	Content					
	HB1034 HB2034	HB1030 HB2030	HB1054 HB2054	HB1050 HB2050	HB1094 HB2094	HB1090 HB2090
Sensor	Fast-Exposure		Back-thinned NIR Enhanced		Fast-Exposure, Back-thinned	
Parameters of Optical System	f/# : 4.5, NA :0.11, Focal Length(R1-R2) :52-60 (It is recommended that the Incident NA should larger than the NA of spectrometer.)					
Dark Noise (Upper Limit)	13 ^{*1} /15 ^{*2}		20		25	
Dynamic Range ^{*3}	5040 ^{*1} /4369 ^{*2}		4370:1		2920	
SNR ^{*4}	330		500		500	
Spectrometer	Crossed Czerny-Turner Optical Structure 2 nd & 3 rd order rejection					
Dimension	83(L) x 75.5(W) x 26.75(H) mm					
Grating	15 grating options ; spectral range from UV to NIR					
Wavelength	From 180 to 1100 nm with a variety of wavelength range					
Slit Size	10, 25, 50, 100, 200,300 um					
Integration Time	0.2ms ~ 65sec, depending on sensors					
Wavelength Repeatability	+/- 0.05 nm Continuous 100 measurements (Hg-Ar Light Source)					
Wavelength accuracy	± 0.15 nm (Testing environment is based on HB2034-050-FUVN. Accuracy may be up to ± 1.0nm according to different environment such as severe temperature change and long-time vibration. OtO can offer WL calibration software if user needed.)					
Resolution(FWHM)	0.2 nm to 10.5 nm, depending on different configuration					
Thermal Stability	<0.04nm/°C					
Environmental Conditions	Storage	-30°C to +70°C				
	Operation	0°C to +50°C				
	Humidity	0% - 90% non-condensing				

*1 : Sensor clock rate 2.5MHz *2 : Sensor clock rate : 10MHz *3 : 65535/Dark Noise(average)

*4 : Single acquisition

- This Document is for business promotion use only.
- For customer's Specification Approval or IQC need, we will provide office Approval Sheet.



OtO Photonics

HummingBird (HB) Series Datasheet

Interfaces	USB2.0@480 Mbps (High speed)
Input Fiber Connector	SMA905: $\Phi 3.18 \pm 0.005 \text{mm}$
	SMA905: $\Phi 3.20 \pm 0.01 \text{mm}$
Recommend Tightening Torque	0.15 Nm (Mating Part : 5mm thick, Flatness 0.1mm, Aluminum sheet)
Power	Power requirement (VBUS): 300mA at +5 VDC Supply voltage: 4.75-5.25, Power-up time : < 4s Maximum USB input power Vcc : +5.25VDC Maximum I/O signal voltage : +5.5VDC

- This Document is for business promotion use only.
- For customer's Specification Approval or IQC need, we will provide office Approval Sheet.

OtO Photonics

HummingBird (HB) Series Datasheet

■ Structure

▶ 3.1 Mechanical Diagram

HBx034 Dual Cable, External M/B type, SMA905

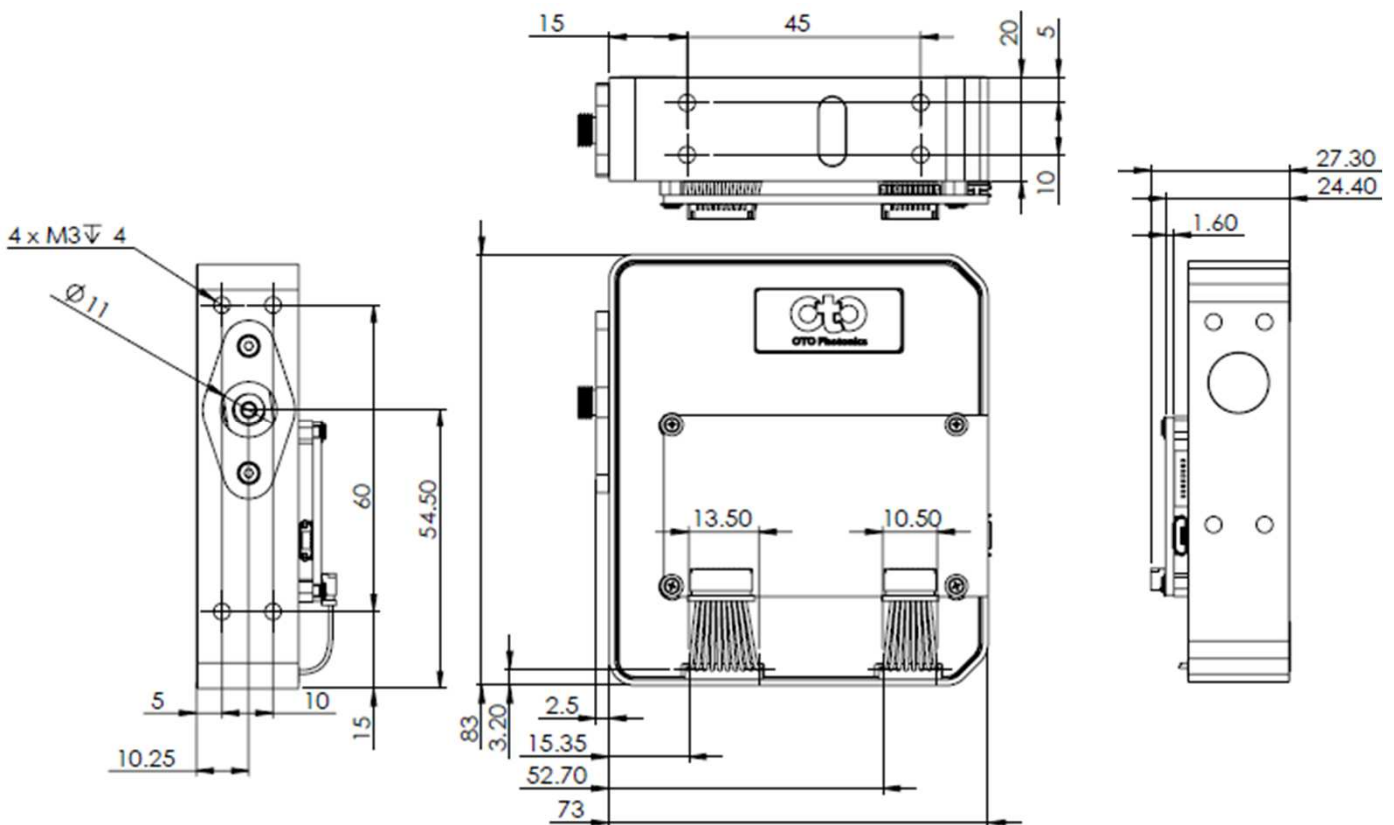

Fig. 1: HBx034 outer dimensions

OtO Photonics

HummingBird (HB) Series Datasheet

► 3.2 Mechanical Diagram HBx054 & HBx094 External M/B type, SMA905

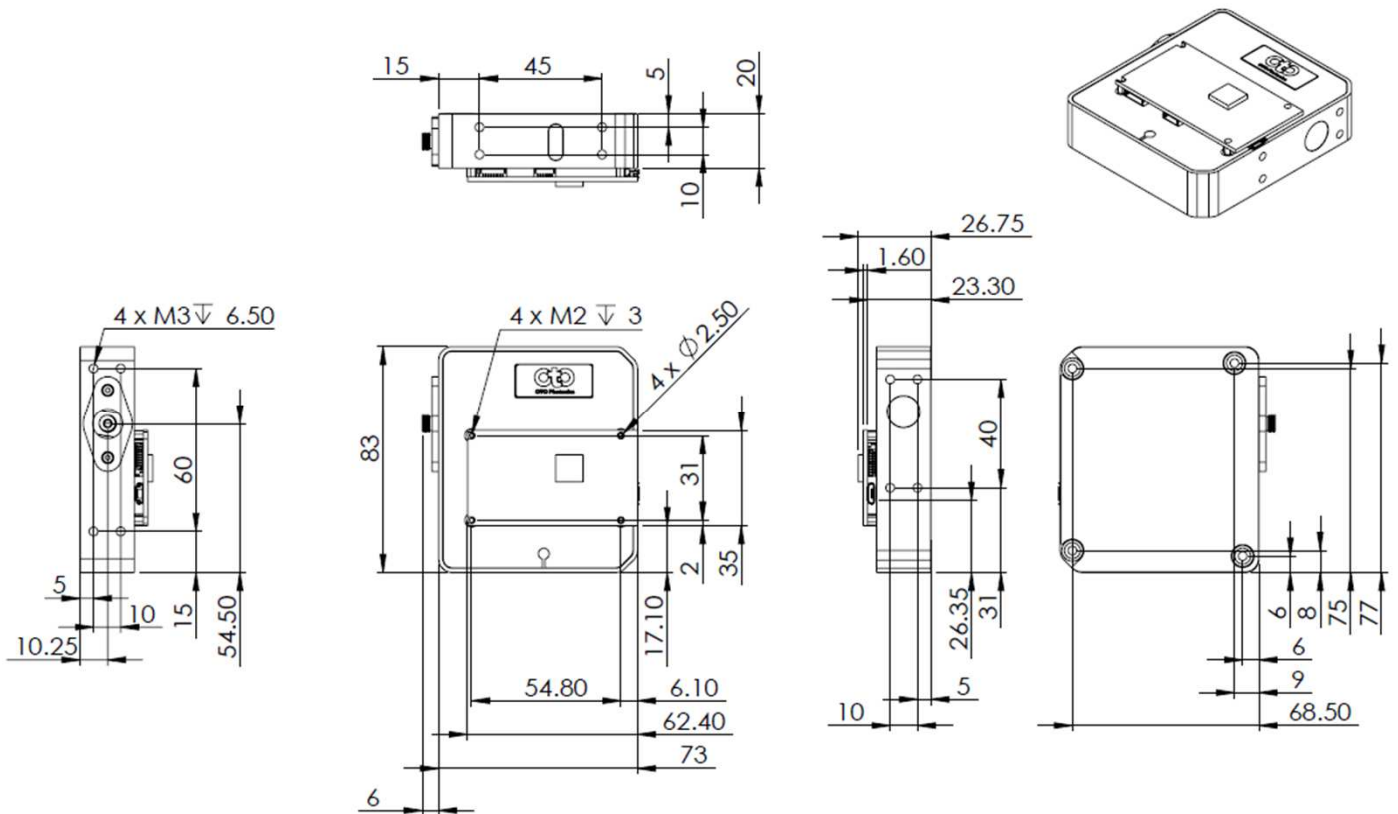

Fig. 2: HBx054 & HBx064 outer dimensions

OtO Photonics

HummingBird (HB) Series Datasheet

► 3.3 Mechanical Diagram HBx054 & HBx094 External M/B type, with out SMA905

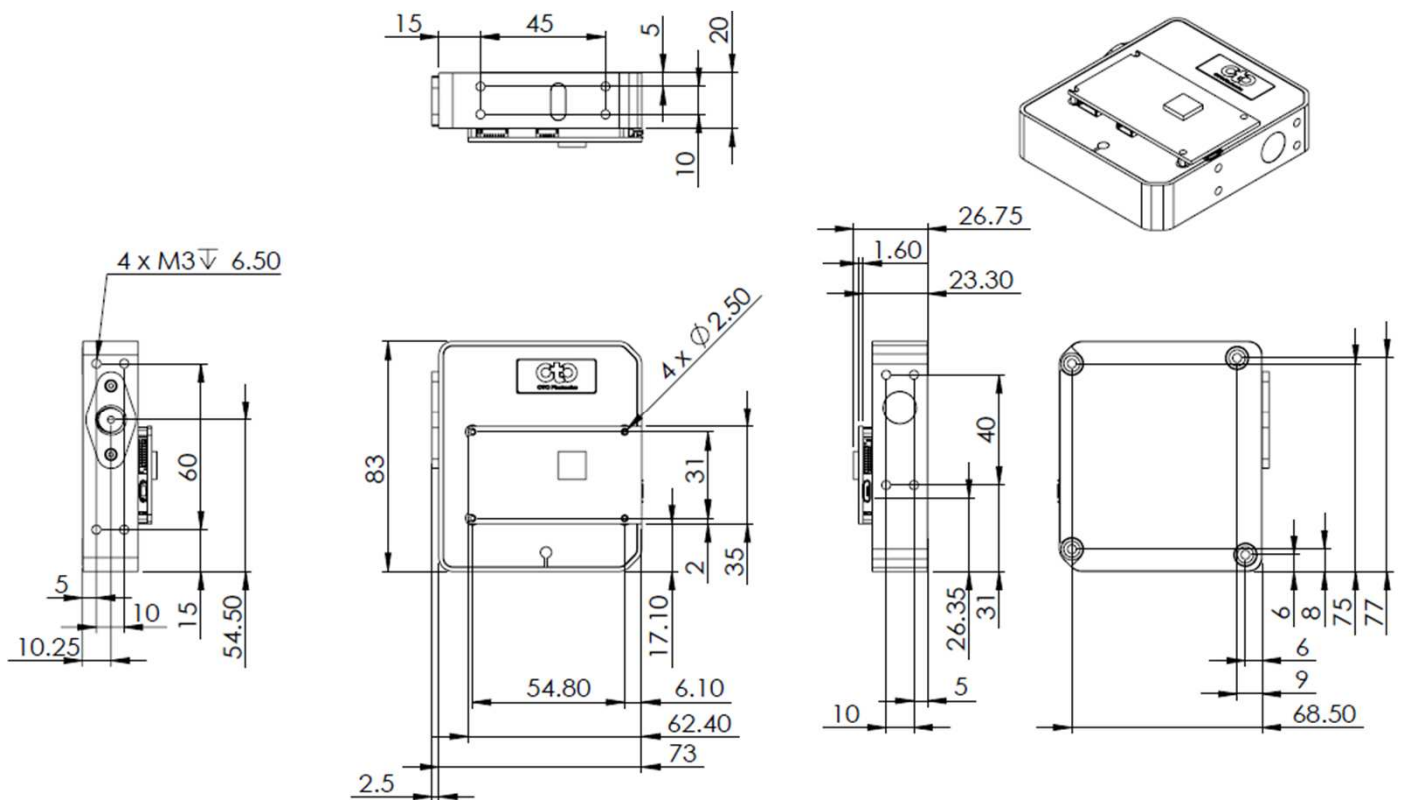

Fig. 3: HBx054L & HBx094L outer dimensions

OtO Photonics

HummingBird (HB) Series Datasheet

▶ 3.4 Electrical Pinout

The following listed is the pin description for the HB Series Extension Connectors. There are two Extension Port (8 pin 1.0mm connector for GPIO, one of them is for OtO debug use), one Micro USB, one USB(4 pin, for special use)

● Pin orientation

Looking HB Series connector side, from left to right are GPIO Extension Port, Micro USB, USB

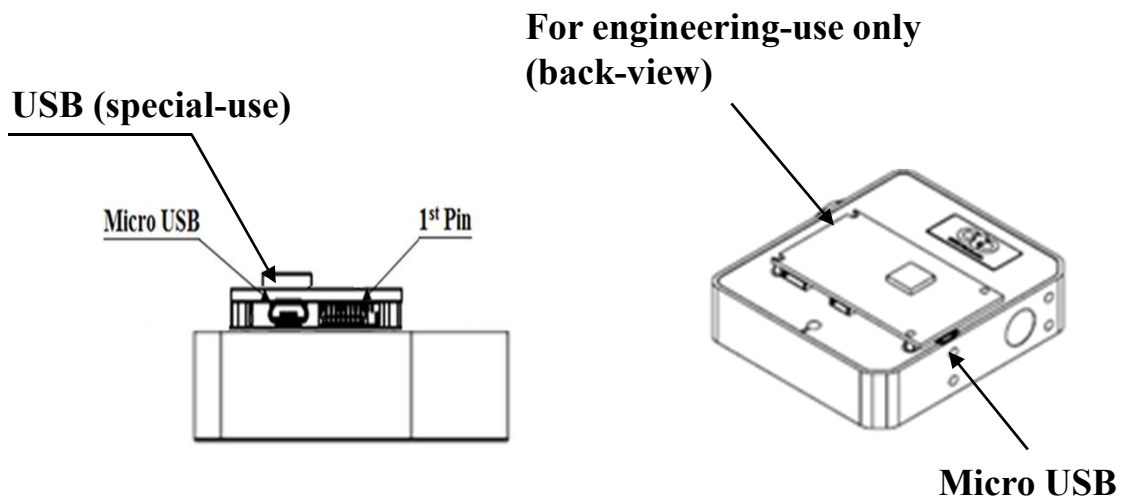

Fig. 4 : HB Series : the front-view of connector mechanical graph

OtO Photonics

HummingBird (HB) Series Datasheet

Back Extension Port Pin# Description Alt Function

*All I/Os are TTL-level input/output

Pin No.	Direction	Pin Name	Function Description
1	Power	5V Output	When connecting to PC USB port, this pin is also connected to VBUS. This pin can provide around 0.1A power for external device.
2	Output	TX	UART TX. TX is the output from the RISC controller.
3	Input	RX	UART RX. RX is the input for the RISC controller.
4	Output	GPIO0	General Purpose Output 0.
4*	Input	RESET	Reset(For HBx03x ONLY)
5	Output	GPIO1	General Purpose Output 1.
6	Output	LS_ON	Light Source Turn ON.
7	Input	Trigger_IN	External Trigger Input Signal.
8	GND	GND	GND

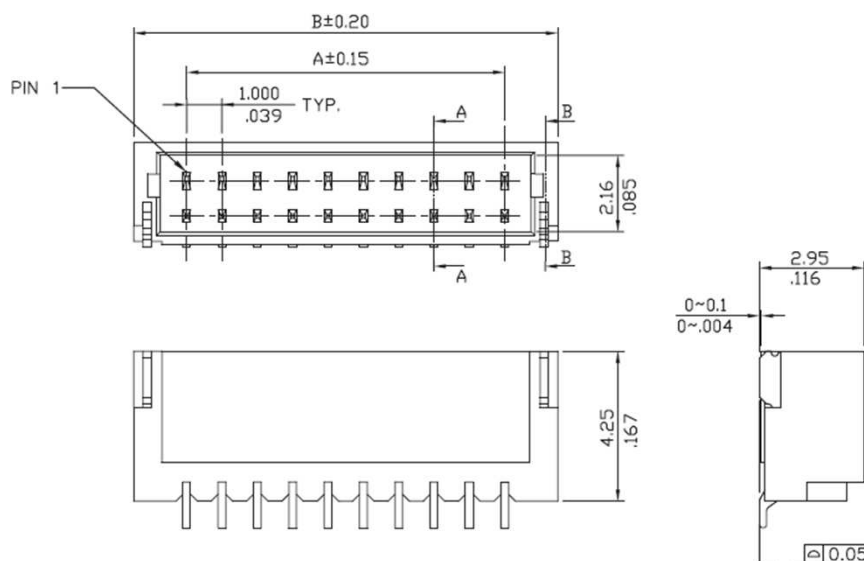

Fig. 5 : Back Extension Port 1.0 mm 8 pin drawing

- This Document is for business promotion use only.
- For customer's Specification Approval or IQC need, we will provide office Approval Sheet.

OtO Photonics

HummingBird (HB) Series Datasheet

USB Port (Special –use)

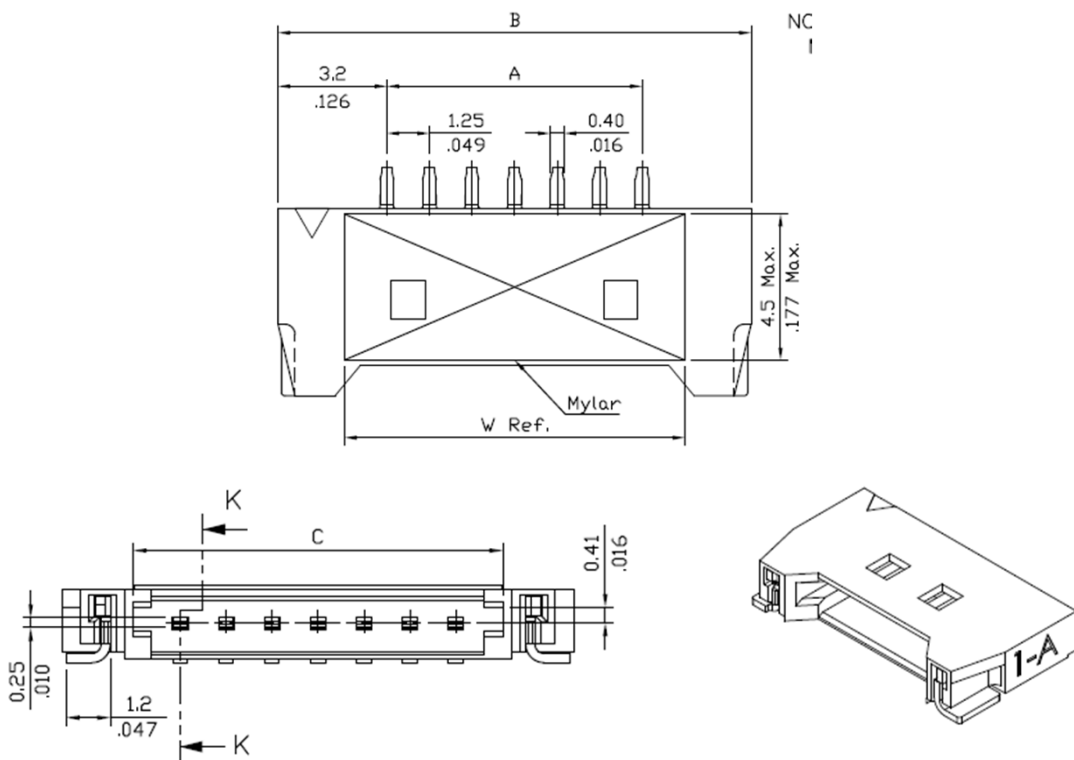

Fig. 6: USB(Special-use) 1.0 mm 4 pin drawing

□ Pin# Description

Pin No.	Direction	Pin Name
1	+5V	+5V
2	Data-	USB-
3	Data+	USB+
4	GND	GND

OtO Photonics

HummingBird (HB) Series Datasheet

▶ 3.5 CCD Overview

● CCD DETECTOR

Hamamatsu S11639/S11510 is a rectangular reduction type CCD linear image sensor designed for optical measuring equipment use. A built-in timing generator and clock-drivers ensure single 5V power supply for use.

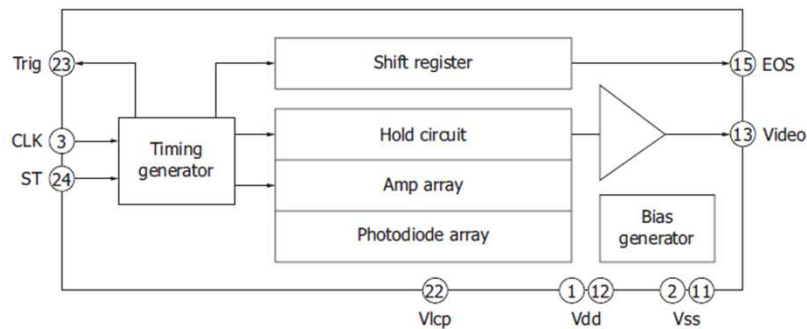

Fig. 7: S11639 CCD Block Diagram

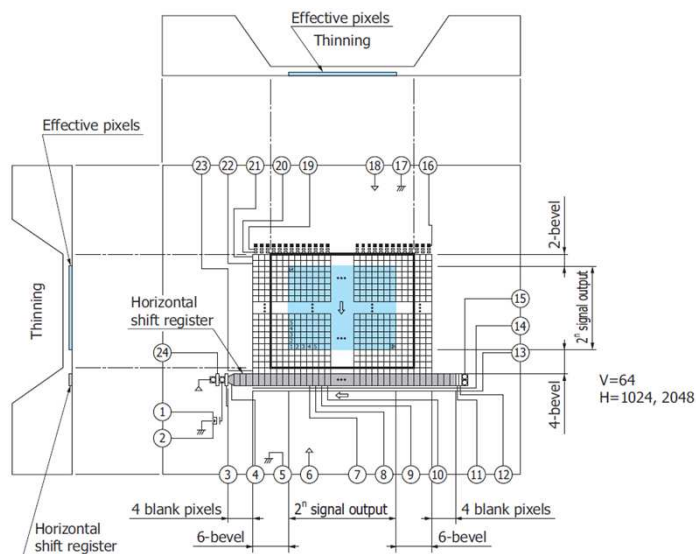

Fig. 8: S11510 CCD Block Diagram

OtO Photonics

HummingBird (HB) Series Datasheet

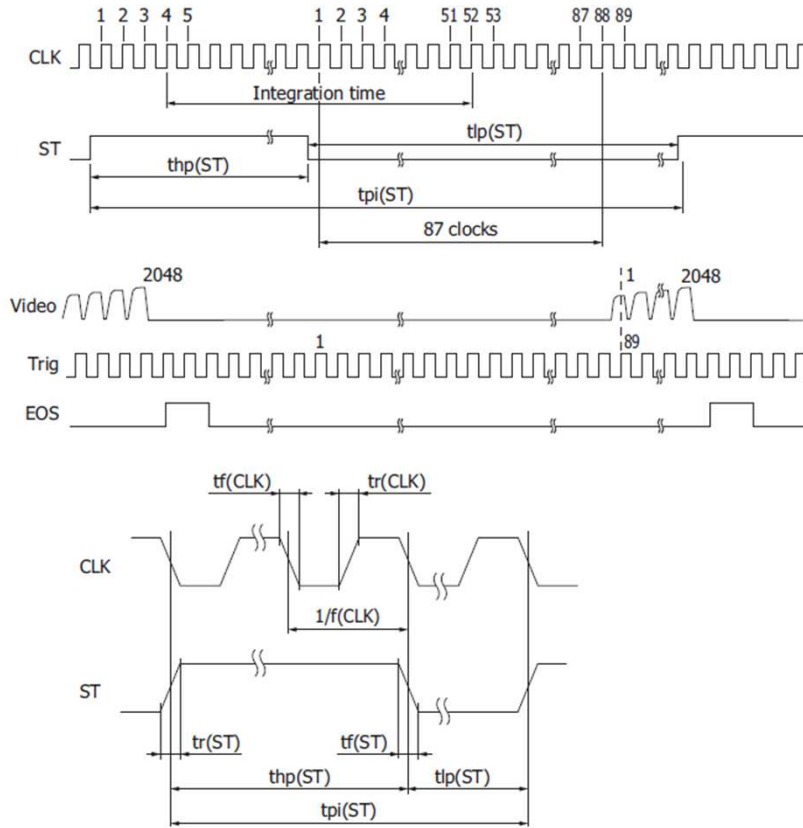

Fig.9: S11639 CCD operation timing waveform

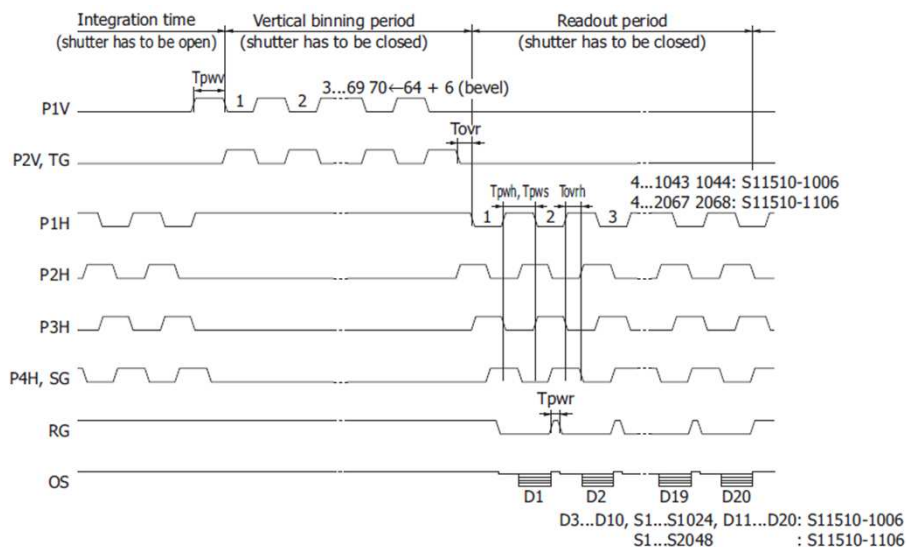

Fig.10: S11510 CCD operation timing waveform



OtO Photonics

HummingBird (HB) Series Datasheet

● CCD/SYSTEM NOISE

There are three major sources impact the Vout signal reading. One is the light source stability, the second is the electronics noise, and the other is CCD detector noise. If we don't consider the outer light source influence, we can check the dark noise performance of this system first. The dark noise we define here is the RMS of Vout signal under 1ms integration time in dark condition. So the dark noise will be only contributed by electronics readout noise and the CCD sensor.

The other major parameter to define the noise performance is the SNR. The SNR we define here is the ratio of the full signal (65535 counts) to the RMS value under the full signal condition. The higher SNR performance indicates the readout signal is more stable. It will be helpful for the low signal differentiation.

● SIGNAL AVERAGING

The software-SpectraSmart provides two options for the signal curve operations. The first one is the signal averaging. By the averaging method, we can reduce the noise impact on each pixel. Surely, more sampling points will bring the better averaging performance. But it will need more time to get one spectra. When we use the time-base type of signal averaging, the S:N increases by the square root of the number of samples. Thus, a S:N is readily 10x achieved by averaging 100 spectra.

The other curve smoothing is boxcar filter. It can average the adjacent points to show the smoother curve, but it will lower optical resolution. So if the target signal is peak type, the boxcar may not be suitable for this.

These two methods can be enabled at the same time if the measurement target is suitable for this operation. But if the user would like to check all the original data and performance, time-based average or boxcar smoothing needs to be un-checked. The default setting for these two average methods is un-checked.

OtO Photonics

HummingBird (HB) Series Datasheet

Internal Operation

4.1 Pixel Definition

The baseline signal is around 1,000 counts in our current system. We can provide the tool/command to manually adjust the baseline. (adjust the AFE OFFSET) The other baseline adjustment method is to enable the background removal from the software. It depends on the user how to use the baseline. Normal output signal is not obtained immediately after device switch on. Use the output signal added 22500 pulses or above to CLK clock pulse.

- The following is a description of all of the pixels

S11639(HB2034)	
Pixel	Decription
1-2048	Optical active pixels

S11510(HB2054)	
Pixel	Decription
1-10	Dummy pixels
11-2058	Optical active pixels
2059-2068	Dummy pixels

4.2 Digital Inputs & Outputs

- General Purpose Inputs/Outputs (GPIO)**

HB Series has 6 user programmable 3.3V digital Input/Output pins, which can be accessed at the 8-pin Extension connector. Through software, the state of these I/O pins can be defined and used for multi-purpose applications. If the user needs the special timing generation (like single pulse or PWM), HB Series provides the flexibility to implement this.

OtO Photonics

HummingBird (HB) Series Datasheet

GPIO Recommended Operating Levels:

VIL(max) = 0.8V

VIH(min) = 2.0V

GPIO Absolute Maximum/Minimum Ratings are as follows:

VIN(min) = -0.3V

VIN(max) = 5.5V

- **Communication and Interface**

USB 2.0

480-Mbit **U**niversal **S**erial **B**us is the standard and popular communication interface in PC. Our PC software allows connecting multiple HB Series via USB and monitors multiple HB Series spectra. The low power requirement allows operating the HB Series through the USB cable and VBUS.

- **Extremely Precise Continuous Multiple Exposures**

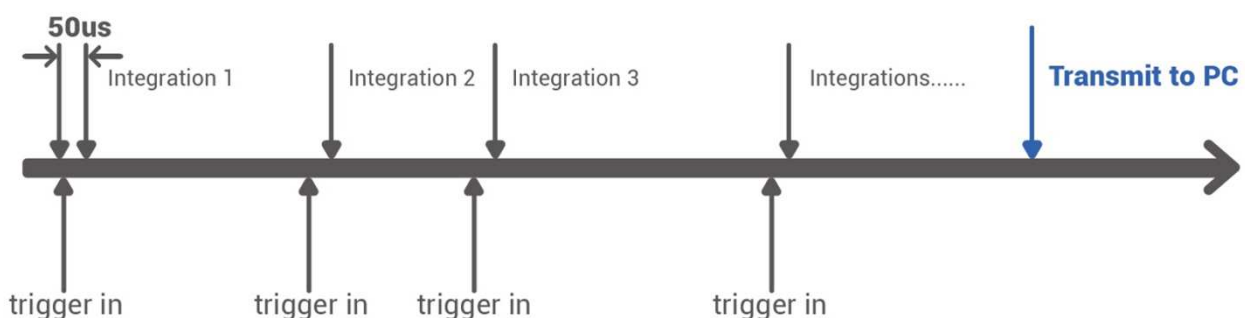

- ❑ Arbitrary integration times
- ❑ Spectra are stored in the huge memory on our board, providing up to 4000 spectra buffering
- ❑ After all integrations are done, the spectra are transmitted to your PC

OtO Photonics

HummingBird (HB) Series Datasheet

▶ 4.3 Trigger Mode

● Single Trigger Single Data

Single Trigger Single Data (integration time has been set by the command first). Spectrometer waits for single pulse to acquire one spectrum. The trigger edge can be set by rising edge or falling edge.

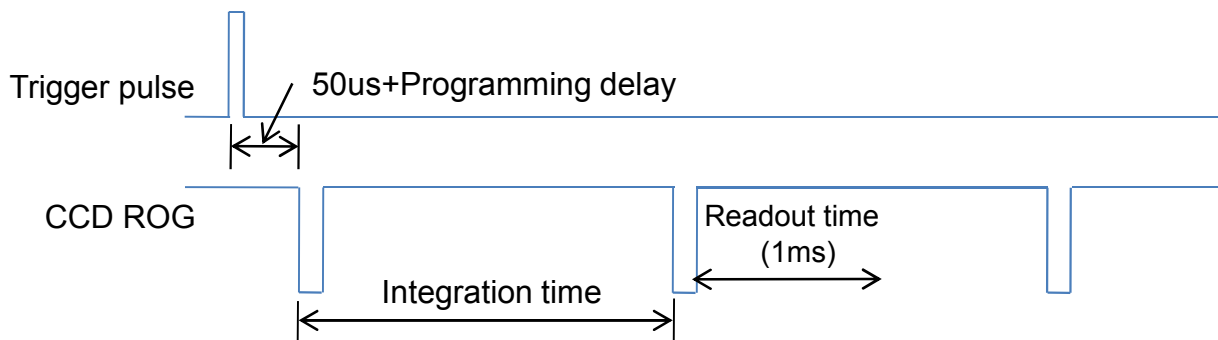

● Single Trigger Multiple Data

Single Trigger Multiple Data (integration time and frame number has been set by the command first). Based on single trigger pulse, the system will continue to capture the spectrums. The data is continuous.

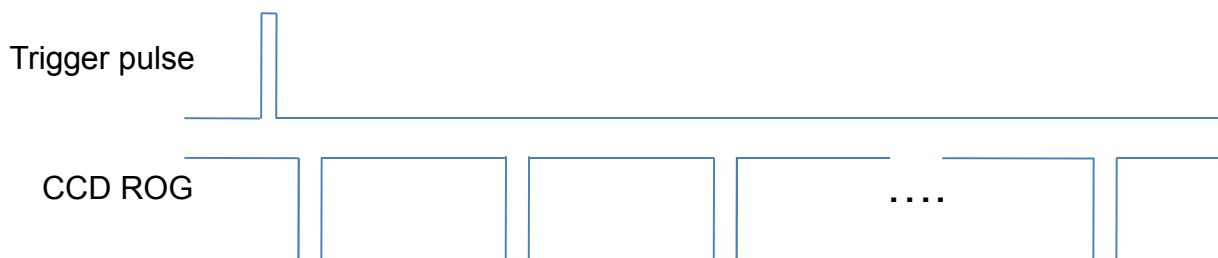

● Multiple Trigger Multiple Data

Multi Trigger Multi Data (different integration times have been set by the command first). Based on pre-setting different integration times, the spectrums will be captured for each trigger pulse.

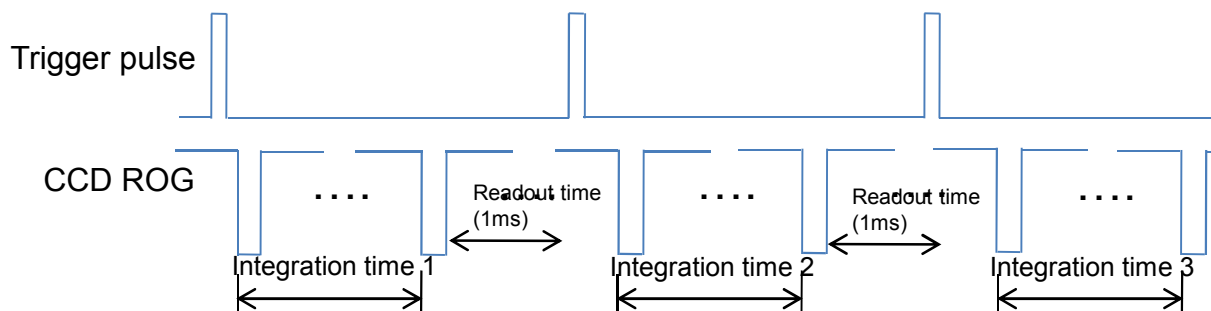

OtO Photonics

HummingBird (HB) Series Datasheet

- **Software Level Trigger**

Software Level Trigger (integration time has been set by the command first, spectrometer waits for external trigger signal). When the trigger signal is high, software will continue to capture the spectrums.

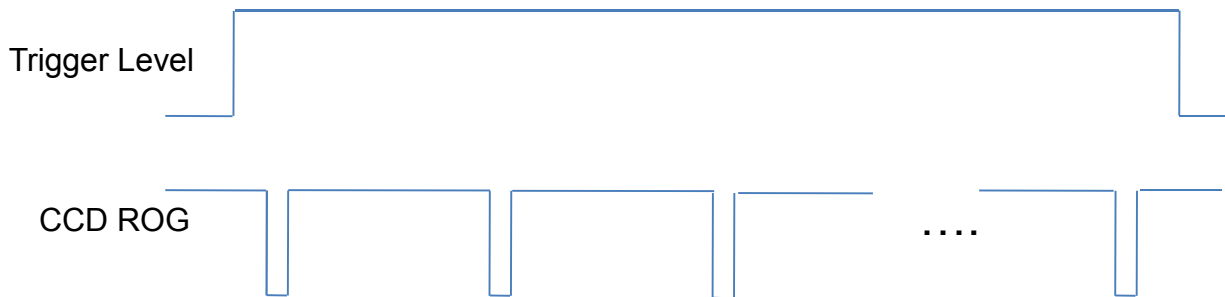

- **Software Level Trigger continuous data**

Software Level Trigger continuous data(integration time has been set by the command first, spectrometer acquires data by command). When the trigger signal is high, software will continue to capture the spectrums even the trigger level is changed to low later.

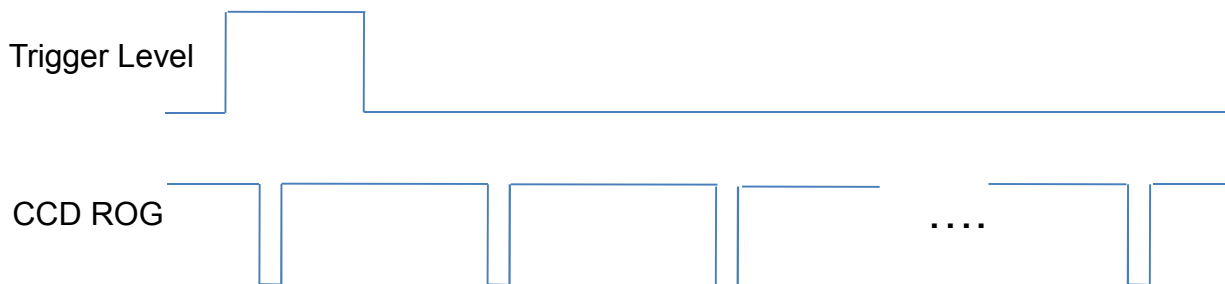

OtO Photonics

HummingBird (HB) Series Datasheet

- **External Trigger control integration time**

In multiple external trigger modes, HB series can support the integration time is controlled by the external trigger signal. Customer can request this kind of trigger mode when placing an order. If customer uses this kind of the spectrometer, the user can configure the HB spectrometer in this kind of operation mode through USB. Then send the external trigger pulse to the spectrometer. The time interval of two trigger pulses is equal to the integration time.

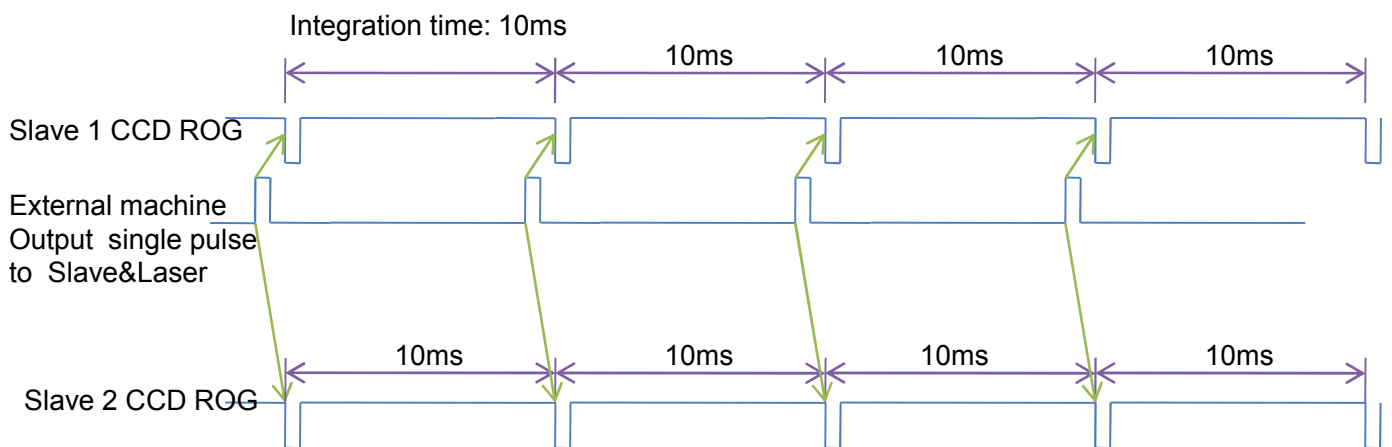

OtO Photonics

HummingBird (HB) Series Datasheet

► 4.4 Ring Buffer

HB series support the ring buffer function to record the continuous spectrum. Customer can request this kind of ring buffer function when placing an order. With this ring buffer function, user can record the continuous spectrum. For example, 10ms integration time, the PC host can receive 360K continuous spectrums in one hour. In this operation mode, the PC host can configure the length of each transfer to save the USB transfer efficiency. The ring buffer can provide the flexibility when the USB transfer is busy for a while. The fast integration time 1ms is supported in ring buffer function.

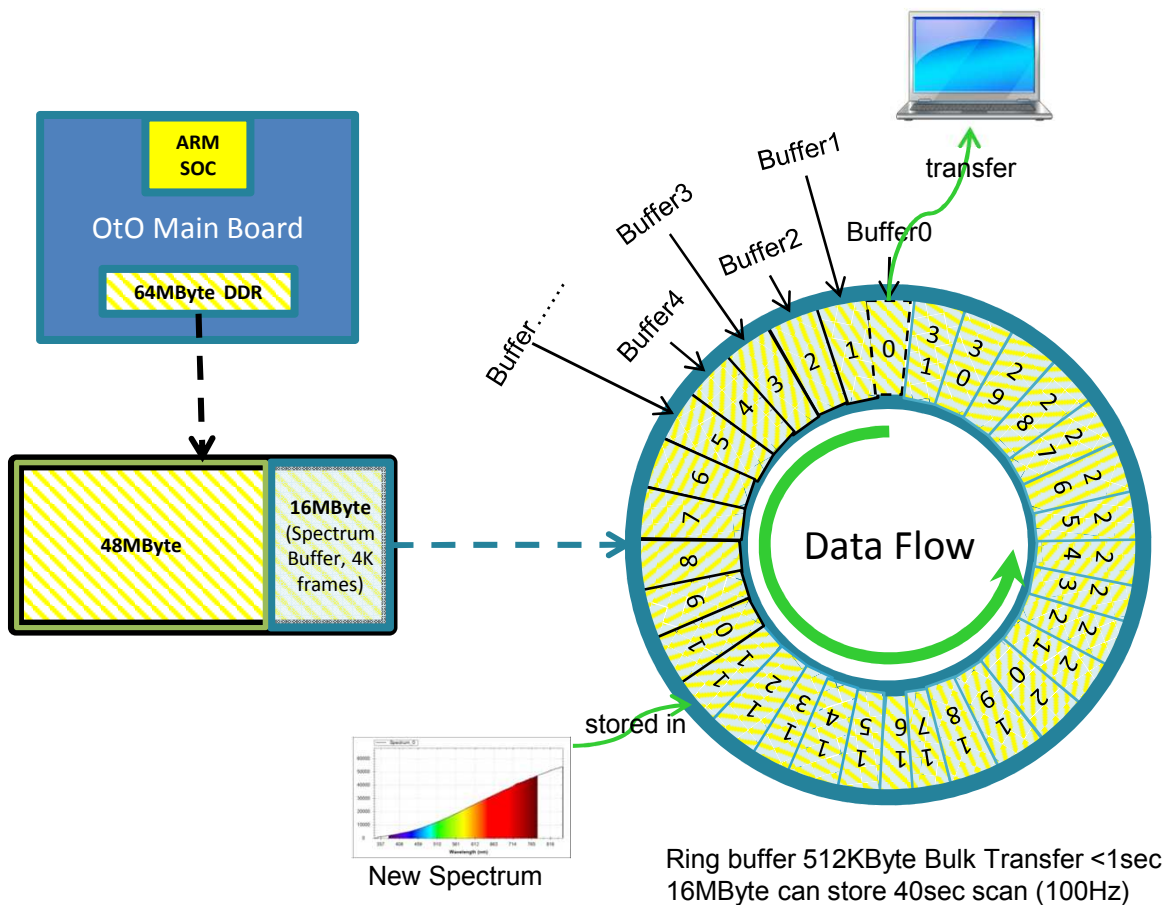



OtO Photonics

HummingBird (HB) Series Datasheet

■ USB Port Interface Communications and Control Information

▶ Overview

HB Series is a microcontroller-based Miniature Fiber Optic Spectrometer that can communicate via the Universal Serial Bus. This section contains the necessary programming information for controlling HB Series via the USB interface. This information is only pertinent to users who wish to not utilize SpectraSmart software to interface to HB Series.

● Hardware Description

HB Series utilizes a 32 bit RISC controller built in USB 2.0. Program code and data coefficients are stored in SPI Flash. The RISC controller supports 32 MByte DDR and 64 Mbits Flash.



OtO Photonics

HummingBird (HB) Series Datasheet

- **USB Info**

HB Series USB Vendor ID number is 0x0638 and the Product ID is 0x0AAC. HB Series is USB 2.0 compliance. The data exchange between host and spectrometer is via bulk streams. The detail USB information please refer USBIF @ <http://www.usb.org>.

- **INSTRUCTION SET**

Application Programming Interface

The list of the APIs is shown in the following table followed by a detailed description of each function call.

- **Open HB Series Spectrometer**

Description: To connect Windows host to HB Series

a.Function Name: UAI_SpectrometerOpen

b.Arguments:

dev: 8 HB Series spectrometers can be attached to one host at the same time. dev is the device number to specify which one will be opened.

handle: the unique Windows identifier to operate devices. Windows will return the identification number which is necessary for further operation.



OtO Photonics

HummingBird (HB) Series Datasheet

❑ Query Frame Size

Description: To get the data frame size of the spectrometer.

a.Function Name: UAI_SpectromoduleGetFrameSize

b.Arguments:

device_handle: a pointer to the device information structure which is returned

when device open.

size: a 16-bit unsigned integer will be returned to indicate the data length.

❑ Acquire Wavelength

Description: Initiates a wavelength acquisition. HB Series will acquire a complete wavelength distribution.

a.Function Name: UAI_SpectrometerWavelengthAcquire

b.Arguments:

device_handle: a pointer to the device information structure which is returned when

device open.

buffer: the storage buffer acquired data.



OtO Photonics

HummingBird (HB) Series Datasheet

□ Acquire Spectra

Description: Initiates a spectra acquisition. HB Series will acquire a complete intensity distribution which corresponds to the wavelength which is acquired by OtO_UAI_SpectrometerWavelengthAcquire.

a. **Function Name:** UAI_SpectrometerDataAcquire

b. **Arguments:**

device_handle: a pointer to the device information structure which is returned when device open.

integration_time_us: a 32-bit unsigned variable to determine the integration time of the micro-seconds.

buffer: the storage buffer acquired data.

average: the spectrum could be averaged by several continuous acquisitions to reduce the noise.

□ Query Wavelength Range

Description: To get the minimum and maximum wavelength

a. **Function Name:** UAI_SpectromoduleGetWavelengthStart

Function Name: UAI_SpectromoduleGetWavelengthEnd

b. **Arguments:**

device_handle: a pointer to the device information structure which is returned when device open.

lambda: a 32-bit floating type data which is indicate the minimum or maximum wavelength, in nm, of HB Series will be returned.



OtO Photonics

HummingBird (HB) Series Datasheet

❑ Query Integration Time Range

Description: To get the minimum and maximum integration time.

a.Function Name: UAI_SpectromoduleGetMinimumIntegrationTime

Function Name: UAI_SpectromoduleGetMaximumIntegrationTime

b. Arguments:

device_handle: a pointer to the device information structure which is returned when device open.

Integration Time: a 16-bit integer type data which indicates the minimum or maximum integration time of HB Series will be returned. The minimum integration time is in micro-second and the maximum Integration time is in milli-second.

❑ Close HB Series Spectrometer

Description: To connect Windows host to HB Series

a.Function Name: UAI_SpectrometerClose

b.Arguments:

handle: the unique Windows identifier to operate devices. Windows will detach the device and any operation is invalid after this function is executed.