

## OEM Calibrators: Hydrogen Cyanide Gas Cell $H^{13}C^{14}N$

Hydrogen Cyanide gas absorption has been widely researched and identified by national standards bodies as a primary wavelength reference in the C-band from 1528nm to 1562nm.

The cells are hard sealed for long life and feature advanced optical design for very low level of interference artifacts. The cells are offered in two standard pressures, 100 Torr recommended for OSA calibration and 10 Torr for tunable lasers.

### The cells are offered in two configurations:

1. With built in low ripple photodiode which is especially useful with tunable lasers.
2. With fiber input and output for applications needing optical output or desiring the flexibility of this configuration.

A tube only option is also available as well as a metal instrument housing which is useful to protect the cell in a laboratory setting. The instrument housing is available with a 1550nm ELED for a broadband source.

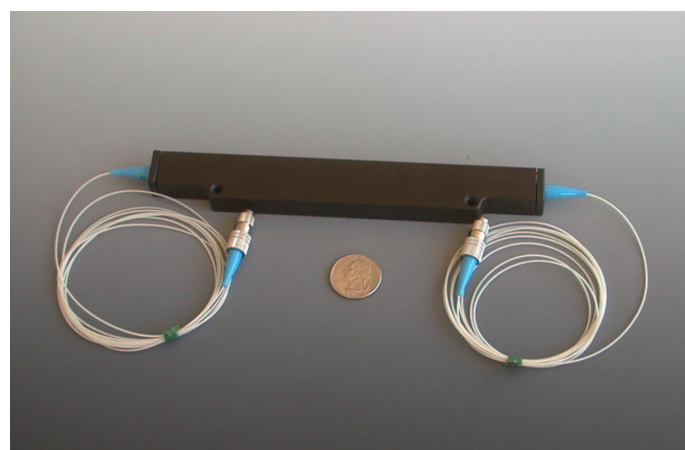

### Specifications (preliminary)<sup>1</sup>

#### Gas Lines:

Wavelength Range	nm	1525nm to 1565nm
Wavelength Accuracy	nm	±0.0003 (1 sigma, 100 Torr)
	nm	±0.00012 (1 sigma, 10 Torr)
Temperature dependence	nm	<0.00001/°C
Atmospheric pressure or humidity dependence		not detectable
Linewidth (-3dB)	nm	0.075 typical (100Torr)
	nm	0.008 typical (10 Torr)
HCN Pressure (25 °C)	Torr	10 to 600 ±10% (custom)
Carbon Isotope		13 standard (12 optional)
Absorption line depth (R9) <sup>2</sup>	dB	3.1 typical (100 Torr)
	dB	2.5 typical (10 Torr)
Interference artifacts	dB	<0.1
Cell Lifetime	years	>20

#### Photodiode:

Net responsivity	A/W	>0.5
Capacitance (0V)	pf	80 typical
Shunt resistance	MΩ	>5

1. Specifications subject to change without notice
2. For instruments that have resolution better than the line width. When probed with lower resolution devices contrast is reduced

### Features

- Reliable hard sealed tube, >20 year life
- AR coated optics and wedged windows for low level of spectral artifacts
- Rugged miniaturized package
- Custom pressure and connectors
- Low cost, aggressive volume discounts
- Full C-band coverage

### Applications

- Embedded calibrator for tunable laser or OSA
- Wavelength locker
- Laboratory Calibration source

### Ordering Information (example)

HCN	-	13	-	C	-	100	-	None
		<b>Isotope:</b>		<b>Type:</b>		<b>Pressure:</b>		<b>Connector(s):</b>
		Standard: 13		Cell with pigtailed: C		Torr		FCPC
		Optional: 12		Photodiode output: CP				FCAPC
				With metal housing: CH				SCPC
								SCAPC
								None

*Wavelength References*

### Wavelength References

14711 S Buckner Creek Rd  
Mulino, OR 97042 USA  
Tel: (503) 632-5240 632-5215(fax)  
Email: sales@wavelengthreferences.com

R Branch	Wavelength (nm)	P Branch	Wavelength (nm)
25	1528.0541	1	1543.1148(6)
24	1528.4862(6)	2	1543.8094
23	1528.9271	3	1544.5147
22	1529.3762	4	1545.2314(6)
21	1529.8376(6)	5	1545.9563(6)
20	1530.3061	6	1546.6902
19	1530.7856	7	1547.4354
18	1531.2764(6)	8	1548.1904
17	1531.7738	9	1548.9554(6)
16	1532.2825	10	1549.7302(6)
15	1532.8024(6)	11	1550.5149(6)
14	1533.3291	12	1551.3106
13	1533.8671	13	1552.1157
12	1534.4159(6)	14	1552.9308
11	1534.9723	15	1553.7560
10	1535.5401(6)	16	1554.5892(6)
9	1536.1170(6)	17	1555.4346(6)
8	1536.7034(6)	18	1556.2919
7	1537.2997(6)	19	1557.1573
6	1537.9069	20	1558.0329
5	1538.5224(6)	21	1558.9185
4	1539.1494	22	1559.8143
3	1539.7855	23	1560.7185(6)
2	1540.4314	24	1561.6344(6)
1	1541.0872	25	1562.5625
0	1541.7529		

**100 Torr Hydrogen Cyanide Spectrum**

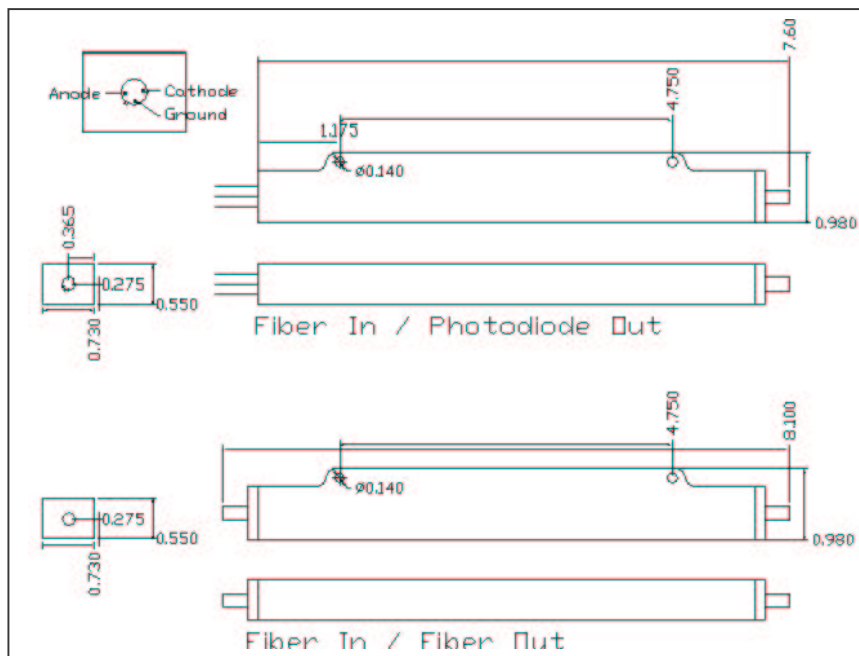

Cyanide gas absorption vacuum center wavelengths of the  $2v_3$  band of  $H^{13}C^{14}N$ . The total uncertainty of these lines is  $\pm 0.0015\text{nm}$  and is dominated by the pressure shift uncertainty. The US National Bureau of Standards and Technology (NIST) has measured 21 of these lines on a similar cell of their own design and certified their center wavelengths with an expanded uncertainty of  $\pm 0.0006\text{nm}$  (coverage factor of 2). Coverage factor of 2 means the uncertainty given is twice the standard deviation (1 sigma). These lines are shown with a (6) in the table. The line centers at low pressure ( $<10\text{Torr}$ ) are known to  $\pm 0.00012\text{nm}$  (1 sigma). For very high accuracy applications involving narrow line widths ( $\ll 0.05\text{nm}$ ), choose a lower pressure.

Safety Note: The total quantity of hydrogen cyanide in a standard cell (100Torr) is about 1 milligram. Small amounts of cyanide are a normal result of metabolism and there is no cumulative effect. For example, the blood of a healthy individual contains about 0.4 milligrams per liter and much more than that if smoking. If the total cell contents were somehow ingested the resultant increase in cyanide would hardly be detectable much less harmful. The OSHA limit for worker exposure is 5 milligrams per cubic meter for an 8-hour shift. For these reasons even in the unlikely event of a cell breakage the small quantity of cyanide in a cell poses no health hazard. In addition for the same reasons the devices can be shipped by any customary means without warning labels. Request our detailed safety analysis for further test data and analysis.

