

2 Micron Tm Fiber Amplifier

AP-AMP1

AdValue Photonics' 2 μ m fiber amplifiers provide many advantages over traditional bulk Ho and Tm solid state systems with their compact size, high efficiency, low maintenance, and ease of use.

Applications:

- LIDAR
- Gas sensing
- Mid-IR generation
- Spectroscopy
- Test and measurement
- Research & development



Features:

- Wide wavelength range
- Adjustable power level
- Diffraction limited beam quality
- Turn-key system with no maintenance

Optical Characteristics:

Parameter	Specification	
	AP-AMP1-2000	AP-AMP1-2100
Model	AP-AMP1-2000	AP-AMP1-2100
Gain wavelength range	1920-2020 nm	2050-2100 nm
Output power (nominal)	1, 2, 5 W (for input at 1940-1980 nm)	1 W (for input at 2070nm)
Power adjustment	10-100% max.	
Output power stability	$\pm 5\%$ (8 hours at 25 °C)	
Beam quality, M ²	< 1.1	
Output polarization	Random (option: polarization maintaining)	
Input/Output fiber	Input: SMF-28 single mode fiber, 3 mm jacket, 1 m length, FC/APC connector Output: SMF-28 single mode fiber, 3 mm jacket, 1 m length, no connector	

(Customization options available.)

Specifications subject to change without notice

General Characteristics:

Parameter	Specification
Operating temperature	10 to +35 °C
Storage temperature	-10 to +70 °C
Cooling	Forced air
Power requirement	AC 100~240V (50/60Hz)
Warm-up time	20 minutes
Package dimensions	448.6(W) x 433(D) x 132.5(H) mm

Mechanical Outline:

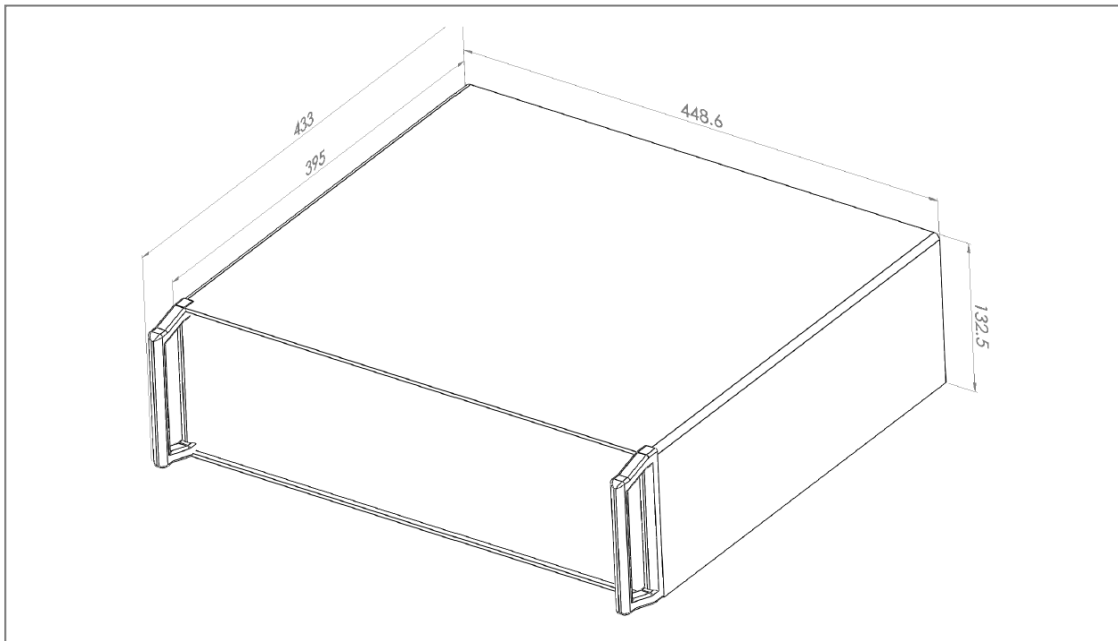

Ordering Information:

Part Number:	AP-AMP1	-	xxxx	-	xx	-	xx		
			Standard Band: 2000 = 1940-1980 nm 2100 = 2050-2100 nm Custom Wavelength: xxxx = xxxx nm		Output Power: 01 = 1 W 02 = 2 W 05 = 5 W		Polarization: RP = random polarization PM = polarization maintaining		

(For special request, please contact AdValue Photonics at 1-520-790-5468 or sales@advaluephotonics.com.)



Specifications subject to change without notice

Innovative products made in the Optics Valley, Tucson, Arizona, USA